

PHYSICS WORKBOOK 2024

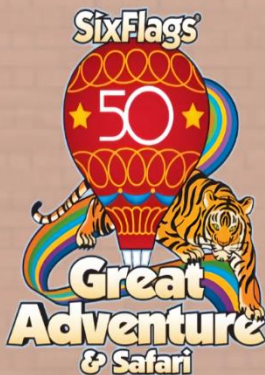

GREAT ADVENTURE RESORT

THEME PARK • WATER PARK • SAFARI • GLAMPING



SIX FLAGS GREAT ADVENTURE PHYSICS DAY WORKBOOK

TABLE OF CONTENTS

RESOURCE MATERIALS

PAGE 2

INTRODUCTION AND LEARNING GOALS

PAGES 3 – 5

MAKING MEASUREMENTS AND USING THE MEASURING TOOLS

PAGES 6 – 7

CIRCULAR MOTION, NEWTON'S 2ND, AND USEFUL PHYSICS FORMULAS



THE ROLLER COASTERS – MAXIMUM THRILLS

PAGES 8 – 12

MEDUSA (FRONTIER ADVENTURES)

PAGES 13 – 16

NITRO (ADVENTURE SEAPORT)

PAGES 17 – 20

EL TORO (PLAZA DEL CARNAVAL)

PAGES 21 – 24

KINGDA KA (THE GOLDEN KINGDOM)

PAGES 25 – 28

BATMAN THE RIDE (MOVIETOWN)

PAGES 29 – 32

SUPERMAN (BOARDWALK)

PAGES 33 – 36

GREEN LANTERN (BOARDWALK)



MAXIMUM THRILLS – NON-COASTERS

PAGES 37 – 39

CYBORG CYBER SPIN (METROPOLIS)

PAGES 40 – 43

SKY SCREAMER (ADVENTURE ALLEY)

PAGE 44

ZUMANJARO (THE GOLDEN KINGDOM)



MODERATE THRILLS

PAGES 45 – 48

DEJA VU (ADVENTURE ALLEY)

PAGES 49 – 52

JOLLY ROGER (LAKEFRONT)

PAGES 53 – 55

THE SWASHBUCKLER (LAKEFRONT)

MILD THRILLS

PAGES 56 – 58

THE CAROUSEL (FANTASY FOREST)

PAGES 59 – 62

THE BUCCANEER (LAKEFRONT)

PAGES 63 – 65

THE BIG WHEEL (ADVENTURE ALLEY)



INTRODUCTION

Physics Day at Six Flags Great Adventure is an outstanding resource for educators to share with their students. It provides students with the unique opportunity to provide first-hand experience for many of the concepts that are taught in the typical Physics I course. Students will experience aspects of acceleration, rotational motion, conservation of energy, and forces – big and small – that are simply impossible to demonstrate in the classroom environment. While the day at the park will be a ‘fun’ activity, it is also a day of hands-on learning and practical application of the topics they have worked throughout the year to master.

LEARNING GOALS

This workbook was designed to meet the needs of the average Physics I curriculum. It focuses primarily on the concepts of:

- Newton’s Laws of Motion
- Force & Acceleration
- Kinematics
- Rotational and Circular Motion
- Work, Power, and Energy
- Conservation of Energy and Momentum

Students will:

- Use tools to collect physical data for analysis
- Predict and calculate forces acting on a rider at different points during a ride
- Calculate the work and power necessary to move riders through a ride
- Calculate centripetal acceleration and normal forces acting on riders in circular motion
- Use the conservation of energy to approximate velocities and altitudes of riders at different points in the ride
- Use rotational motion equations to determine linear speed of riders in circular motion

INSTRUCTIONAL PREPARATION

It is important to review the main topics that the students will be using to complete this workbook prior to your day at the park. There are additional resources available from Six Flags that can be very useful in your review, specifically the “*Great Adventure Physics Day Review & Samples*” and “*Great Adventure Assignment for Students not at the Park*” workbooks. These were created using rides that were removed / replaced.

Familiarize yourself with the terminology of the workbook. Teachers use different variables and terms to describe forces and situations. This workbook tries to use variables and terms that are generally universal, but they may be different than what you use with your students. Examples:

- The Acceleration Meter (Accelerometer) measures the net acceleration acting on you at any given time. Some teachers refer to this with terms such as “*g-force*”, “*force factor*”, “*acceleration rate*”, or “*g-reading*”. This workbook uses the term “Acceleration Factor” to describe this acceleration. It is important that students understand how to read the meter and that the meter is providing an acceleration reading in multiples of the acceleration due to gravity.
- The use of the term “Normal Force” describes the contact force between a rider and their chair or the force between a roller coaster train and the track.
- Many of the problems can be solved independent of the mass of the rider. However, some questions (particularly those involving energy calculations) are dependent on rider mass. For simplicity this workbook will assume a common mass of 60 kg for all theoretical riders.

Please feel free to make additions and amendments to this workbook as you feel necessary to better facilitate its use for your individual group of students. I hope that you find this workbook useful and valuable to your experience at Six Flags Great Adventure.

Regards,

Tom Paterson, Physics Instructor

MAKING MEASUREMENTS AND CALCULATING ANSWERS

Most measurements can be made while waiting in line for the ride, such as timing specific events. Acceleration Meters can only be used on certain rides for safety considerations, and therefore less of these readings are required. Be sure that the Acceleration Meter is securely attached to your wrist using the rubber band or safety strap while using it during the ride.

The workbook is designed for you to answer each question using your knowledge of Physics to find an exact answer. There are also multiple-choice answers that are provided to help you determine if your calculated answer is appropriate. **Realize that the answer you calculate may not / should not exactly match a potential multiple-choice answer.** These potential answers have been created using actual measurements from previous years. Therefore, you should choose the multiple-choice answer **that most closely matches** what you have calculated using your measurements. **Provide your exact solutions in the box provided** and show the accompanying work and calculations in the space provided for that question.

Instructor note: students will have to use specific given mass assumptions so that the multiple choice answers will work. Also, the assumption is that the Acceleration Meter readings that the students record will give comparable to established values.

IMPORTANT TERM: “ACCELERATION FACTOR”

Acceleration Factor (AF): An acceleration factor enables you to express the magnitude of an acceleration that you are experiencing as a multiple of the acceleration due to gravity. This is also referred to as the **g-force** (even though we are not actually measuring force) or simply how many “g’s.” This acceleration is usually the result of the ride’s seat pushing on you to hold you up or change the direction that you are moving.

Acceleration Factors are very useful in making our measurements because while all riders will experience different forces while riding (because the force is dependent on rider mass, which varies person to person) each rider will experience the exact same acceleration.

If a rider needs to determine the individual force that they feel while riding they simply need to multiply their mass by their measured acceleration factor. For example, while standing still everyone experiences an acceleration factor of 1g (the acceleration due to gravity) and therefore the force acting on any person in this scenario is: $F_g = mg$ where g = the acceleration factor and m is the mass of the person.

To measure an Acceleration Factor: The Acceleration Meter **must be held in the direction of acceleration**. If you are moving in a circle, the Acceleration Meter should be pointed so that it is pointed towards the center of the circle. (This is considered the positive direction for circular motion.) **For most rides you will simply need to hold the acceleration meter perpendicular to the floor of the train/ride.**

EXAMPLES OF HOW TO USE AN ACCELERATION FACTOR

When you measure an Acceleration Factor:

EQUAL to 1, you feel **NORMAL**, you feel a force on your seat exactly equal to your weight as the seat supports you.

GREATER than 1, you **FEEL HEAVIER** than normal and feel pressed into the chair. In reality, the chair is pressing up on you which you interpret as being pushed down.

LESS than 1, you **FEEL LIGHTER** than usual and can feel as if you are almost lifting out of the chair. For example, this is how you feel when an elevator starts down suddenly. It is possible to have acceleration factors that are less than zero (negative) where you would feel like you are being thrown upwards (you would lose contact with your seat), however the acceleration meters are not capable of measuring this quantitatively.

For example: On a certain ride a 50 kg girl uses the acceleration meter to record an Acceleration Factor of 3. This corresponds to an acceleration of 3 g’s – three times the acceleration of gravity.

- What is acceleration that she is feeling as measured in m/s^2 ?
 - $3 \times 9.8 \text{ m/s}^2 = 29.4 \text{ m/s}^2$
- How heavy does this rider feel while experiencing this acceleration factor?
 - $F = ma = (50 \text{ kg})(29.4 \text{ m/s}^2) = 1,470 \text{ N}$

USING THE ACCELEROMETER AND OTHER MEASURING TOOLS

There are three main tools you will need to make your measurements required to complete the questions in this workbook. You will need (at a minimum):

- Acceleration Meter*
- Angle Meter
- Stopwatch / Timer

For each set of ride questions, you will see this box: It will tell you what tools are needed to make your measurements. Note: Angle Meter readings and timing events never need to be taken while riding. Only acceleration meter readings must be taken while riding.

Measurement Tools Required		
Acceleration Meter	Angle Meter	Stopwatch / Timer
NO	NO	YES

The Acceleration Meter (Accelerometer) and Angle Meter can be purchased from online sources or they can also be homemade with a little ingenuity. Modern smartphones are able to make all of these measurements with the appropriate applications installed, however the precision is often not sufficient on roller coasters based on sampling rates and the limitations on the range measured as compared to more dedicated acceleration meters.



Acceleration Meter



Angle Meter / Horizontal Acceleration Card



Stopwatch

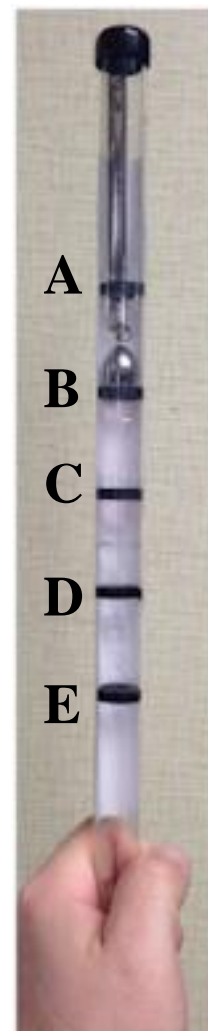

To use the Acceleration Meter hold it in the direction you are trying to measure. Most of the accelerations that you will measure are the result of going in a circle, so you would hold the meter with the top end pointed towards the center of the circle you are moving in. In most cases this will be perpendicular to the floor of the ride/roller coaster train.

The Acceleration Meter is usually a plastic tube with a mass suspended from a spring. There should be markings on the side of the tube in order to determine the acceleration reading. In the figure to the right the mass is the oval shaped dot in the tube. The person holding this tube is at rest, so the mass is at (B) and the net acceleration they feel is $1g - 9.8 \text{ m/s}^2$ – the acceleration due to gravity.

When on a ride, if the mass falls down to the second mark (C) that indicates that the rider is feeling an acceleration of $2g - 19.6 \text{ m/s}^2$. At the third mark (D) the acceleration would be $3g - 29.4 \text{ m/s}^2$. Most acceleration meters should have markings down to at $4g$ (E).

When riders feel lighter than they normally would (such as in freefall, or going over the top of a ‘camel hump’ on a roller coaster) the mass will move upwards to record an acceleration less than that of gravity. At point (A) on the meter the rider would feel $0g - 0 \text{ m/s}^2$ – weightlessness. It is also possible that the riders can experience negative g 's while riding (the feeling of being thrown upwards and out of the seat), however these acceleration meters are not capable of measuring negative g 's and will simply show $0g$.

*Because of the current park policies and safety considerations, acceleration meters may not be taken on most rides to make measurements. The workbook questions are modified to account for this, but it is still important for students to understand the basic principles of the acceleration meter.

MAKING MEASUREMENTS

Angle Meter / Horizontal Acceleration Card:

Hold the Angle Meter so that its top or bottom side is parallel to the angle you are trying to measure.

There are three ball bearings inside the plastic tube that will move to indicate the angle. Record the angle value for the MIDDLE ball bearing.

On roller coasters you should be able to place the angle meter on the side armrest of the train to measure the angle.

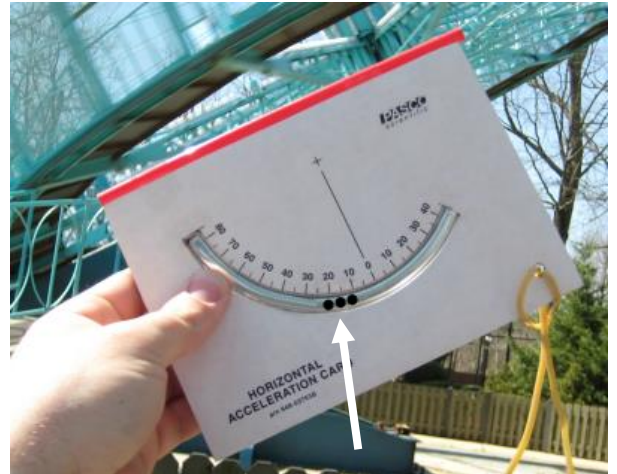

Measuring the time for a train to go over the top of a hill:

You will need to make a time measurement using your stopwatch to determine how long it takes a roller coaster train to pass a particular point.

Choose a fixed point on the hill – it should be the highest point. (See arrow in figure on left)

Start the stopwatch when the front of the train reaches your chosen point.

Stop the stopwatch when the rear of the train passes your chosen point.

You can calculate the train's velocity using your measured time and the length of the train. $v = d / t$

Measuring the time to go up a lift hill:

Begin the stopwatch when the train reaches the base of the lift hill, and stop it when it reaches the top. (See arrows in figure on right)

You can either make your measurement using the front of the train or the rear of the train as your reference point – but choose one and stick with it.

Do not start the measurement when the front of the train begins up the hill and stop it when the rear of the train reaches the top!



FREE BODY DIAGRAMS AND NEWTON'S 2ND LAW IN CIRCULAR MOTION

In order for an object to move in a circle, there must be some force acting on it that is pointed towards the center of the circle (the radial direction). The purpose of this force is to change the direction of the motion the object. In order to determine how large this unbalanced radial force must be, Newton's second law is applied.

$$\Sigma F_R = \frac{mv^2}{r}$$

- F_R is the radial force; the positive direction for this force is towards the center of the object's circular motion.
- m is the mass of the object moving in circular motion
- v is the linear velocity of the object
- r is the radius of the object's motion as it travels in circular motion

When a person on a ride experiences circular motion (as on a roller coaster) the major forces acting on them are their weight and the contact force between the person and their seat. Summing these forces allows for the radial force to be determined, from which other information (such as velocity or radius of motion) can be determined.

The key to correctly analyzing forces for riders in circular motion is drawing the proper free body diagram. Some sample free body diagrams for riders at different points are shown below:

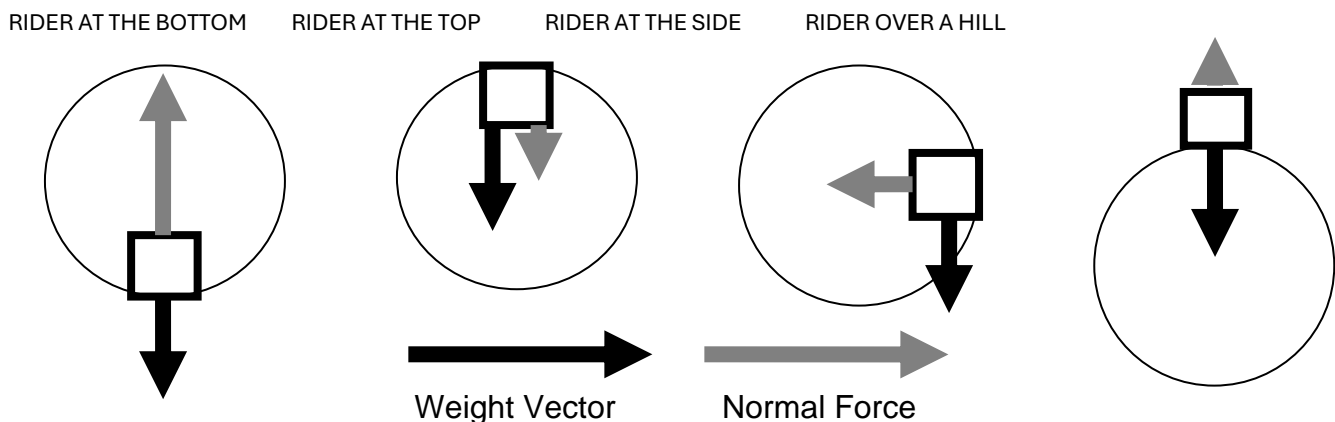

The Acceleration Meter readings that you will take while riding tell you the amount of "g-force" that is acting on your body. One "g" is equal to the acceleration due to gravity. Two "g's" is twice the acceleration due to gravity, and so on. When you are at rest or moving at constant velocity the net acceleration acting on you is 1g acting on you (this is the regular force you feel due to the Earth's gravity). When your body is accelerated by a ride the force on you is increased due to this acceleration. Since every rider on a ride is accelerated at the same rate, but do not feel the same force (because each rider has a different mass, and $F=ma$) it is very convenient to use "g-force" to analyze forces when solving problems.

The reading you take with the Acceleration Meter tells you what force you feel acting on your body. If the meter reads 2 g's, then you feel a net acceleration double that of gravity and therefore you feel twice as heavy. Let's illustrate with an example:

A rider going through a circular loop on a roller coaster records a g-force reading of 0.5 when they are at the top of the loop (see picture above – 2nd from left). The rider is moving at 15 m/s and the radius of the loop is 15 meters. What is the magnitude of the force that they feel?

$$\Sigma F_R = \frac{mv^2}{r} = F_N + mg$$

$$F_N = \frac{mv^2}{r} - mg$$

$$F_N = \frac{(60\text{kg})(15\frac{\text{m}}{\text{s}})^2}{15\text{m}} - 60\text{kg}(10\frac{\text{m}}{\text{s}^2}) = 300\text{N}$$

USEFUL PHYSICS FORMULAS

Kinematic Equations

$$\Delta d = d_f - d_i \qquad v = \frac{d_f - d_i}{t} \qquad a = \frac{v_f - v_i}{t} \qquad v = v_i + at$$

$$d = v_i t + \frac{1}{2} at^2 \qquad d = \frac{1}{2} t(v_f + v_i) \qquad v_f^2 = v_i^2 + 2ad$$

Translational (Straight Line) Motion

Newton's Second Law: $F_{NET} = \Sigma F = ma$ Force of Friction: $F_f = \mu F_N$

Work = $Fd = \Delta KE$ Kinetic Energy = $KE = \frac{1}{2} mv^2$ Power = $P = E / \Delta t$

Gravitational Potential Energy = $PE = mgh$

Total Energy of a System = $PE + KE = \frac{1}{2} mv^2 + mgh$

Linear Momentum of an object = $p = mv$

Impulse = $I = F\Delta t = \Delta p = m\Delta v$

Rotational (Circular) Motion

Circumference = $C = 2\pi r$

Diameter = $D = 2r$

Period = T

Frequency = f

$$T = \frac{1}{f}$$

Velocity = $v = \frac{2\pi r}{T}$

Centripetal Acceleration = $a_c = \frac{v^2}{r}$

Centripetal Force = $F_c = ma_c = m \frac{v^2}{r}$

Newton's 2nd Law for Rotational Motion: $F_{NET} = \Sigma F_R = \frac{mv^2}{r}$

Right Angle Trigonometry

$$\sin \theta = \frac{O}{H}$$

$$\cos \theta = \frac{A}{H}$$

$$\tan \theta = \frac{O}{A}$$

$$a^2 + b^2 = c^2$$

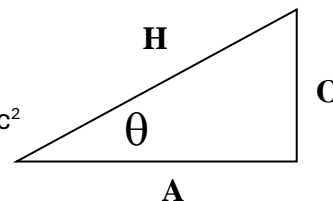

Conversion Factors

1 meter (m) = 3.28 feet (ft)

746 Watts (W) = 1 horsepower (hp)

9.8 Newtons (N) = 2.2 Pounds (lbs)

1 kilogram (kg) is equivalent to 2.2 pounds (lbs)



Measurement Tools Required		
Acceleration Meter	Angle Meter	Stopwatch / Timer
NO	NO	YES

Mass of the train: 2700 kg
 Average Passenger Mass: 60 kg
 Angle of the Lift Hill: 25 degrees



Train Passenger Capacity (total # of seats)	Total Mass of Train + Riders (kilograms)	Time for Train to climb Lift Hill (seconds)

MEDUSA CONSERVATION OF ENERGY DATA TABLE

Point on Height vs. Time Graph	Height above reference point (m)	Potential Energy (kJ)	Kinetic Energy (kJ)	Total Mechanical Energy (PE+KE) (kJ)	Velocity (m/s)
A			N/A	N/A	N/A
B			**	**	
C					
D					
E					
F					
G					
H					
I					
J			N/A*	N/A*	N/A*

* Total Mechanical Energy is not conserved due to braking forces between Points I&J. See the 9th and 10th M/C questions for Medusa.
 ** Answer the 2nd M/C question before calculating these values.

MEDUSA - HEIGHT VS. TIME

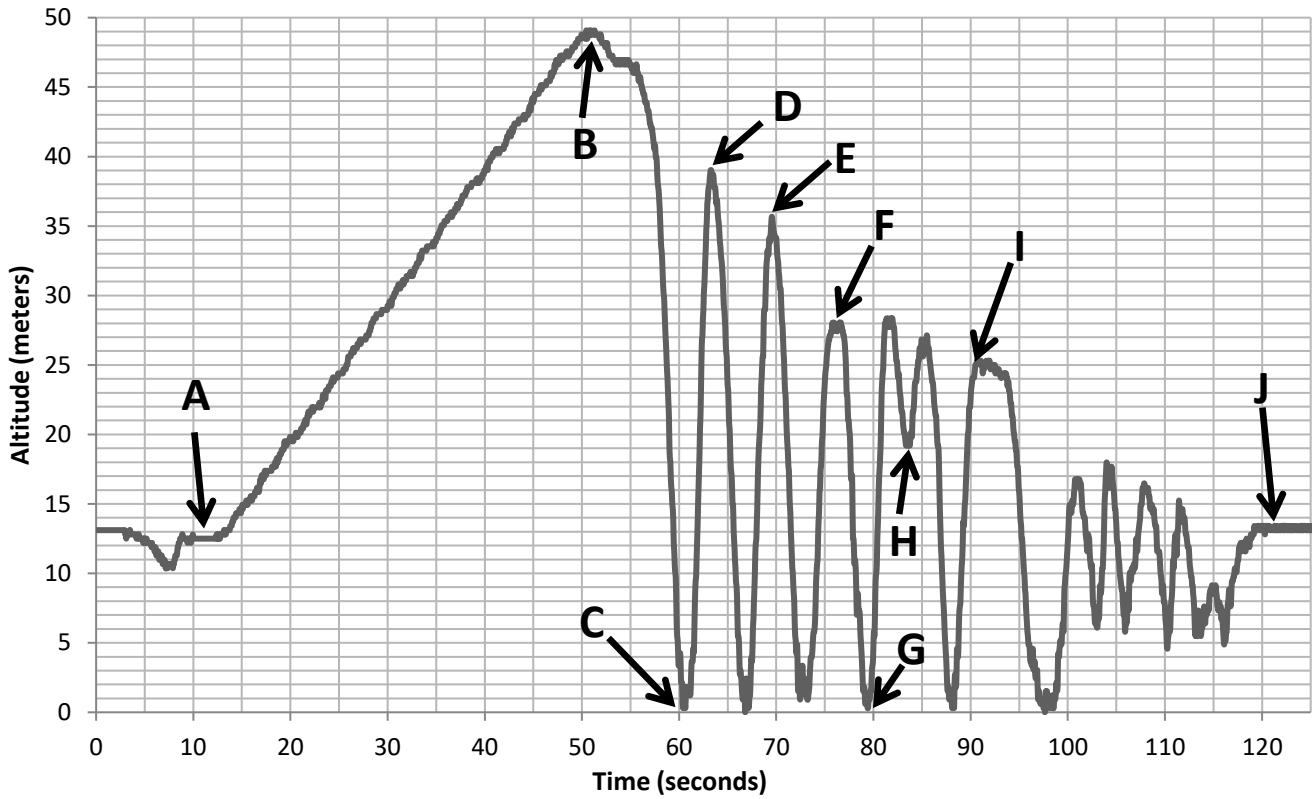

Use Altitude = 0 meters as a reference point for all calculations

MEDUSA - ACCELERATION METER READING VS. TIME

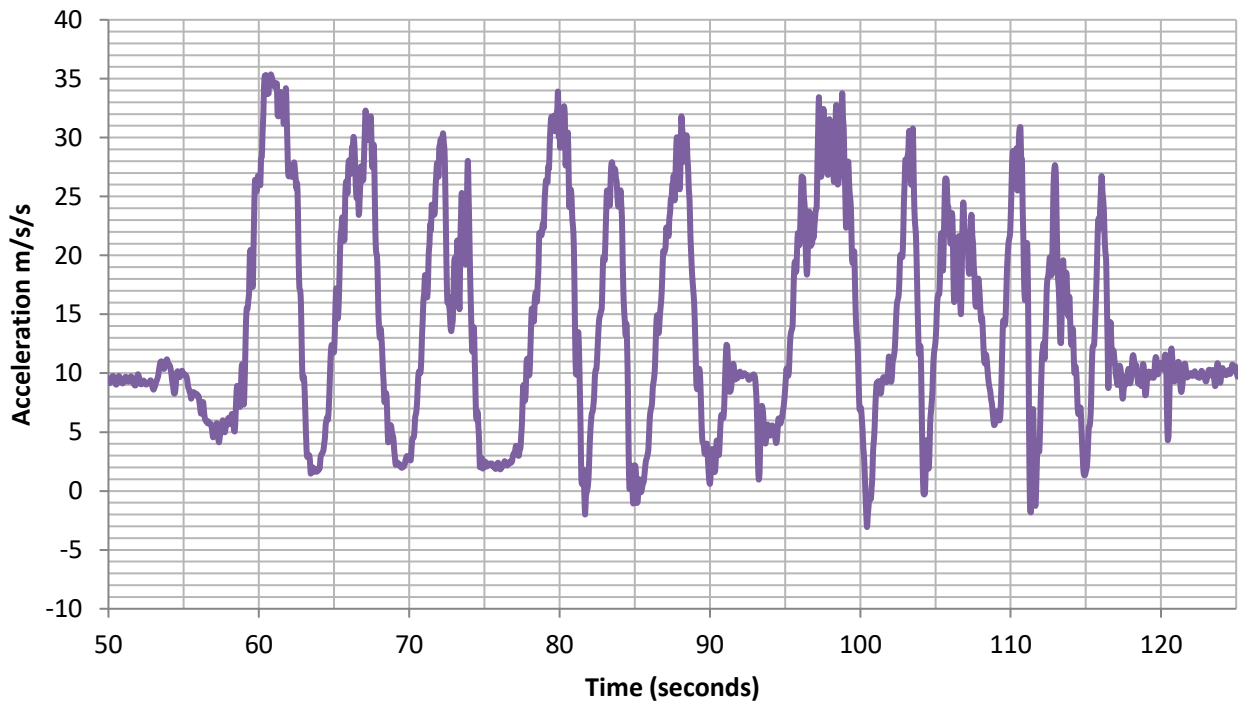

NOTE: The time values on both graphs are correlated to each other.

1) Calculate the work done by the roller coaster's electric motor to increase the train's gravitational potential energy by raising it up the lift hill (fully loaded with all passengers) from Point A to Point B (see Altitude vs. Time Graph).

- a) 65,000 J b) 100,000 J c) 165,000 J d) 660,000 J e) 1,650,000 J

2) What was the average linear velocity of the train as it climbed the lift hill? (This is the velocity the train will have at the top of the hill and will allow you to calculate the Kinetic Energy of the train at point B.)

- a) 0.5 m/s b) 2.2 m/s c) 4.9 m/s d) 7.2 m/s e) 9.8 m/s

3) What is the minimum average power required from the roller coaster's electric motor to move the train and raise it up the lift hill (fully loaded with all passengers) in the time you measured?

- a) 5 hp b) 20 hp c) 40 hp d) 60 hp e) 80 hp

4) What is the change in the fully loaded train's Potential Energy between Points B and C?

- a) 165,000 J b) 660,000 J c) 1,250,000 J d) 2,200,000 J e) 3,450,000 J

5) What is the velocity of the train at point C?

- a) 39 m/s b) 31 m/s c) 24 m/s d) 19 m/s e) 15 m/s

6) What is the velocity of the train at point E?

- a) 32m/s b) 28 m/s c) 24 m/s d) 20 m/s e) 16 m/s

7) What is the velocity of the train at point H?

- a) 36 m/s b) 30 m/s c) 24 m/s d) 19 m/s e) 15 m/s

8) At Point H, the train is tilted sideways so that force of gravity and the normal force acting on the rider are roughly perpendicular to each other. As a result the only force in the radial direction is the normal force (the only centripetal force). What is the approximate radius of the curve the rider is traveling through at point H? (Hint: use the acceleration graph to determine the normal force on the train at Point H.)

- a) 12 m b) 16 m c) 22 m d) 28 m e) 32 m

There are two braking platforms to first slow, and then stop, the train before it returns to the station for rider exiting. The first one is just past Point I (where the train is slowed), and the second is at Point J (where the train is stopped for queuing into the station).

9) The braking platform near Point I applies a braking force (opposite to the direction of the train's motion) resulting in an acceleration of -6 m/s^2 for approximately 1.5 seconds. How fast is the train moving when it leaves this braking platform?

- a) 28 m/s b) 23 m/s c) 18 m/s d) 13 m/s e) 8 m/s

10) At Point J the train is slowed down to nearly a full stop in order to prepare it to return to the station. When it enters this point it is moving at a velocity equal to the velocity it left Point I's braking platform (previous question) plus the velocity it gained from the train's change in potential energy between points I and J. The distance that the train is slowed down over is 20 meters (the length of Point J's braking platform). What is the horizontal acceleration of the train while it is braking?

- a) -2.2 m/s^2 b) -4.9 m/s^2 c) -10.5 m/s^2 d) -14.6 m/s^2 e) -19.2 m/s^2

OPEN ENDED QUESTIONS:

LEVEL I: Examine the Acceleration Meter Reading vs. Time graph. Notice that the maximum acceleration that the rider feels while going through turns is roughly the same throughout the ride at approximately 3 g's (~30 m/s/s). Using the table you completed compare the energy and velocity the train has at Points C & G. As a result of comparing the train's acceleration factor (read this from the graph provided), energy, and velocity, what can you say about the radius of curvature at points C and G? What is the approximate numerical value for this radius, in meters?

LEVEL II: Medusa is a roller coaster that constantly changes the orientation of the rider as they go along curves and through loops. Point C, D, and G (on the Height vs. Time graph) are curves where both the rider's weight (force of gravity) and normal force are along the radial direction. At Points E, F, and H the train is tilted so that the rider's weight and normal force are not in the same direction. Draw a free body diagram for a rider at each of these points using the figures below. The circle represents the object, and the curved line represents the direction of the track's curve. Solve mathematically for the approximate radius of the curve at each point.

Points
C,G:

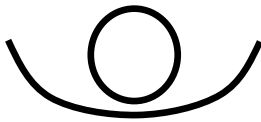

Point
D:

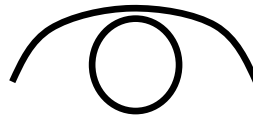

Points
E,F,H:



Radius at Point: C _____ D _____ E _____ F _____ G _____ H _____

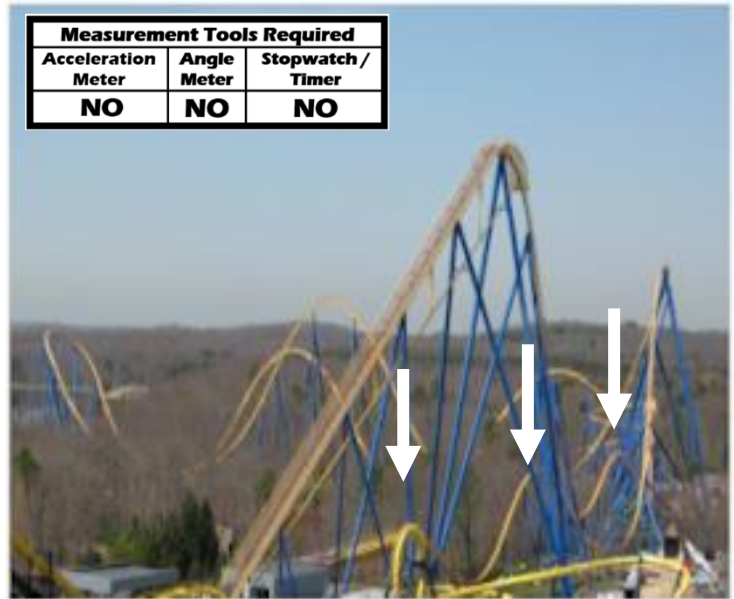

Measurement Tools Required		
Acceleration Meter	Angle Meter	Stopwatch/Timer
NO	NO	NO

Measurements to Make:

About 1 minute into the ride you will go through a braking platform followed by a series of three “camel humps” immediately before returning to the station.

(See pictures on right and on the top of next page.)

In this section you will experience a range of acceleration factors between 0.5 and 2.5. Pay attention in this section and determine if which value most likely corresponds to the top and bottom of each hump. (Circle the correct value)

Acceleration Factor at the top of the hump: **0.5 or 2.5**

Acceleration Meter at the bottom of the hump: **0.5 or 2.5**

Radius of curvature at camel humps: 35 m

Mass of the train: 2100 kg

Rider mass: 60 kg

“Camel Hump” section

11) Nitro’s initial vertical drop is 65.6 meters. What is the potential energy of the train just before it falls?

- a) 500,000 J b) 750,000 J c) 1,000,000 J d) 1,300,000 J e) 1,600,000 J

12) The length that the train is pulled up the lift hill is 120 meters (in order to reach the 65.6 m vertical drop height). How much force did the lift chain apply to the train to pull it up the hill?

- a) 500 N b) 1500 N c) 7500 N d) 12,000 N e) 18,000 N

13) If we assume that the velocity of the train is nearly zero right before it falls, then what is the velocity of the train at the bottom of this initial drop?

- a) 5 m/s b) 15 m/s c) 25 m/s d) 35 m/s e) 45 m/s



“Camel Humps”

14) Calculate the work done by gravity on you during the initial drop.

- a) 5,000 J b) 10,000 J c) 20,000 J d) 30,000 J e) 40,000 J

15) At the bottom of the first drop you experience approximately 4 g's (39.2 m/s^2). What is the approximate radius of curvature at the bottom of the initial drop?

- a) 11 m b) 22 m c) 33 m d) 44 m e) 55 m

16) The train rises back up to 148 feet (45 meters) to get to the top of the next hill. According to the conservation of energy the velocity of the train at the top of this hill should be 20 m/s, but instead it is measured to be 15 m/s. An engineer inspects the track and finds that 10 meters of a flat section have been damaged and is no longer frictionless. What is the coefficient of friction over these 10 meters of track?

- a) 0.5 b) 0.6 c) 0.7 d) 0.8 e) 0.9

17) In the camel hump section of the ride, based on your Acceleration Meter reading and radius of curvature for the hump, what is your velocity at the top of the camel hump?

- a) 5 b) 15 c) 25 d) 35 e) 55

18) Draw a free body diagram for a rider going over the top of a camel hump, and another diagram for a rider at the bottom of a camel hump (the box is the rider, the half-circle represents the radius of curvature for the hump). What is the difference between these two scenarios when applying Newton's 2nd Law for circular motion?

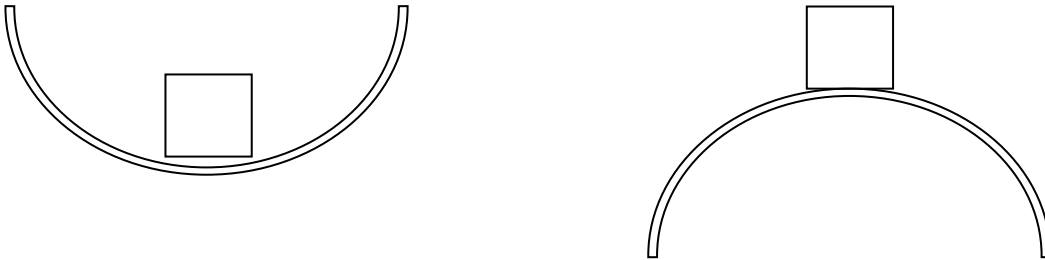

- a) There is no difference
- b) When going over the top of the camel hump, the force of gravity vector is pointed up
- c) The normal force is in the positive direction at the bottom of the hump and in the negative direction at the top
- d) There is no normal force when going through the bottom of the camel hump
- e) The force of gravity and the normal force are not in the radial direction

19) In the camel hump section of the ride, based on your Acceleration Meter reading and radius of curvature for the hump, what is your velocity at the bottom of the camel hump?

- a) 5
- b) 15
- c) 25
- d) 35
- e) 55

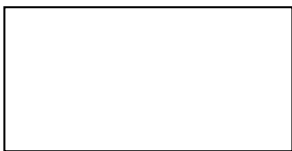

20) What is the main reason for incorporating “camel humps” into the ride?

- a) To slow down the train right before it returns to the station
- b) To give the rider the alternating low-g and high-g acceleration in a short time period
- c) To give the train enough momentum to make it back to the station
- d) To keep the cost of manufacturing the ride low
- e) It makes the ride look pretty

OPEN ENDED QUESTIONS:

The graph below shows Altitude (top solid line) and Acceleration (bottom dashed line) vs. time.

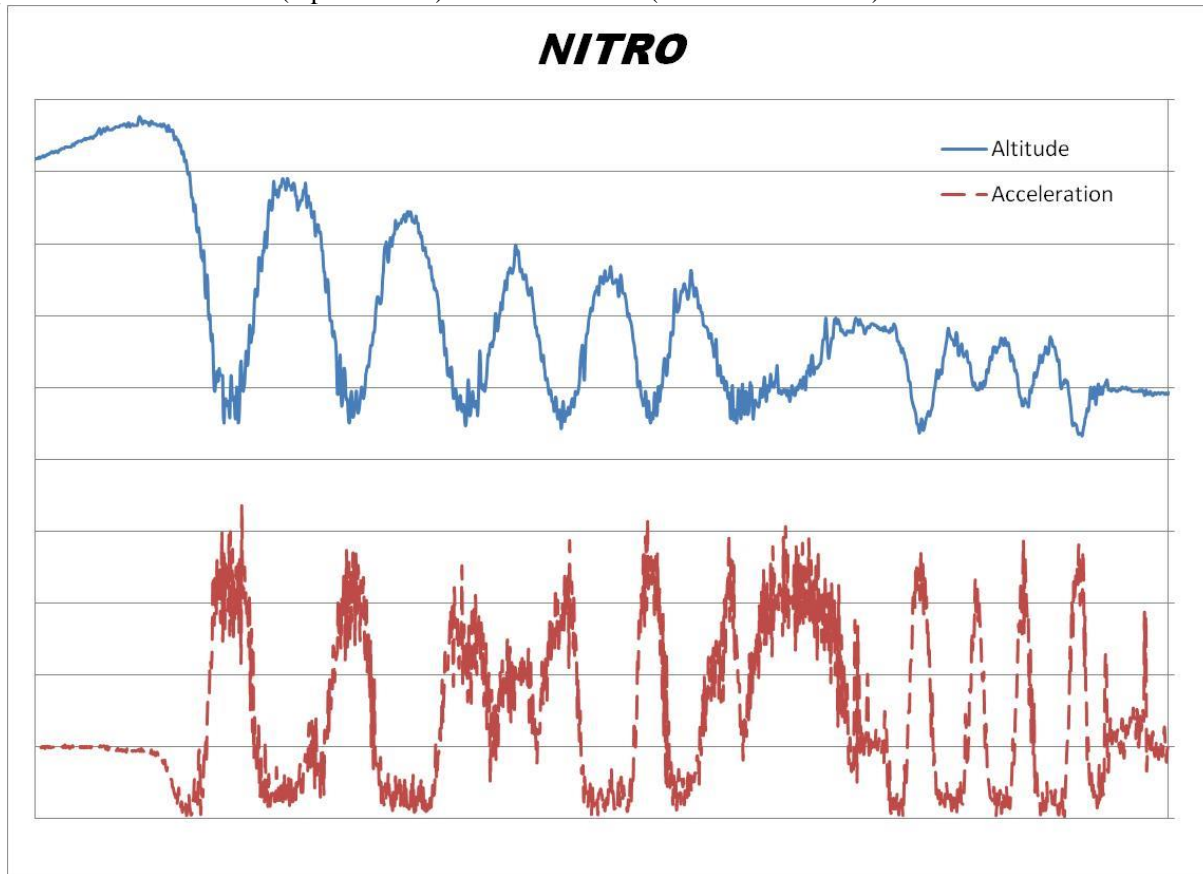

LEVEL I: On the Altitude section of the graph the last three 'bumps' represent the camel hump section that was the subject of the previous questions. What do you notice about both the Altitude and Acceleration graphs for this section? How are they similar and different when compared to themselves and each other?

LEVEL II: The Altitude graph shows that as the ride progresses each successive hill is lower than the previous one. Is this what you see in the Acceleration graph also? Describe the acceleration graph and explain why engineers designed the ride to achieve these results. If the ride does slow down the farther that it goes, how does the ride still achieve the acceleration results you see in the graph?

EL TORO



Measurement Tools Required		
Acceleration Meter	Angle Meter	Stopwatch / Timer
NO	NO	YES

Measurements to make:

While observing: Go to the area behind El Toro (near the bridge that crosses the pond). Watch the train as it goes up the lift hill and record the time it takes for the front of the train to go from the bottom to the top of the hill.

Time for the front of the train to reach the top of the lift hill (Points A to B):

Time 1	Time 2	Time 3	Time 4	Time 5
Average:				

Time for the train to pass over the top of the second hill (Point C):

Time 1	Time 2	Time 3	Time 4	Time 5
Average:				

Angle of the lift hill: 36°

Instruments may not be taken on the ride – meter readings are provided:

Acceleration Meter reading at the bottom of the first drop hill: 4.0

Acceleration Meter reading going over the top of the next hill: -1.0*

*We turned the meter upside down to get this result. What does it mean?

21) El Toro's train goes up the lift hill much more quickly than other roller coasters usually do, however it is still moving at nearly constant velocity. What would you expect the Acceleration Meter reading to be while going up this hill if you were asked to measure it? Why?

- a) 0 b) 1 c) 2 d) 3 e) 4

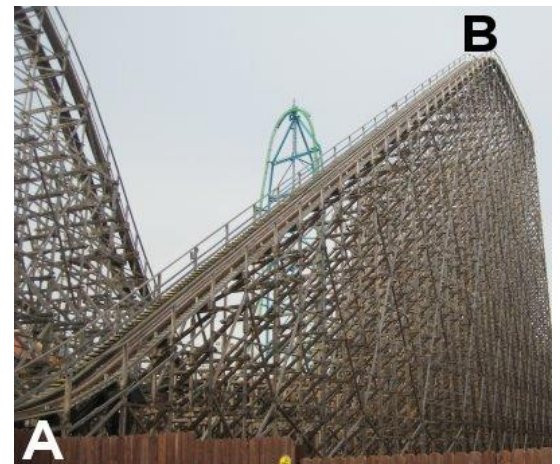

- 22) To get to the top of the lift hill El Toro's train is vertically lifted by 53.3 meters. The average mass of a loaded (train with passengers) El Toro train is 9750 kg. What is the work done by the motor to lift the train and passengers to the top of the hill?
- a) 100 kJ b) 1000 kJ c) 5000 kJ d) 10,000 kJ e) 100,000 kJ

- 23) If El Toro's lift hill was steeper (greater angle) but just as high (same height), then would the work required to bring the train from the bottom to the top be:
- a) More b) Less c) The Same

Why?

- 24) Given the angle that you measured for the lift hill and its height of 53.3 meters, what is the average amount of force is required to push the train to the top?
- a) 500 N b) 5,000 N c) 50,000 N d) 500,000 N e) 5,000,000 N

- 25) Using the time you measured for the train to reach the top of the hill, what is the minimum output power of the motor that is used to pull the train up the hill?
- a) 300 W b) 3 kW c) 30 kW d) 300 kW e) 3 MW

- 26) If El Toro's lift hill was steeper (greater angle) but just as high (same height) and the amount of time it took to get the train from the bottom to the top was the same, would the minimum power output of the motor be:
- a) More b) Less c) The Same

Why?

27) Using the Acceleration Meter reading that you measured when you reached the bottom of the first drop hill, what was your approximate speed when you were at this point? The radius of the curve at the bottom of the hill was 29 meters.

- a) 10 m/s b) 20 m/s c) 30 m/s d) 40 m/s e) 50 m/s

28) If you assume that El Toro's velocity before the first hill's drop was very small (assume zero) in comparison to its speed at the bottom of the drop hill, what was the approximate height of the drop hill?

- a) 5 m b) 25 m c) 45 m d) 75 m e) 125 m

29) The length of El Toro's train is 18.8 meters. Using your measurement for the amount of time it took El Toro to go over the top of the next hill, calculate the speed that the train was moving.

- a) 10 m/s b) 20 m/s c) 30 m/s d) 40 m/s e) 50 m/s

30) When you go over the next hill you experience the feeling of being thrown out of your seat (good thing you have a seat belt). This means that you are subjected to negative g's. The value of this acceleration is approximately 1g (9.8 m/s^2) in a direction away from the center of the curve (up). Why would you have to turn the acceleration meter upside down to get this reading? Using the speed you calculated in the previous question and an acceleration value of $-1g$ (-9.8 m/s^2), what is the approximate radius of the curve for this hill?

- a) 10 m b) 20 m c) 30 m d) 40 m e) 50 m

OPEN ENDED QUESTIONS:

LEVEL I:

Below is a graph of Train Height vs. Time for El Toro. The section labeled A indicates the train going up the lift hill, at section B the train was turning and getting ready to drop, at section C the train is going down its first drop, at section D it is at the bottom of the first drop hill and so on. Given this graph, indicate how the rider feels (normal, heavier, lighter) at each point (A – I).



POINT	FEELING
A	
B	
C	
D	
E	
F	
G	
H	
I	

LEVEL II:

Use the graph above to create a plot of Acceleration Meter reading vs. Time.





Measurement Tools Required		
Acceleration Meter	Angle Meter	Stopwatch / Timer
NO	NO	YES



All measurements for this ride can be made while observing the ride. Please do not bring instruments on the ride as there is no need to take any readings while riding.

Record the time it takes the train to reach the top of the hill (from Point A to B):

Time 1	Time 2	Time 3	Time 4	Time 5
Average:				

Record the time it takes for the length of the train to pass over the top most point (Point B):

Time 1	Time 2	Time 3	Time 4	Time 5
Average:				

Record the time it takes for the length of the train to pass over the camel hump (Point C):

Time 1	Time 2	Time 3	Time 4	Time 5
Average:				

The launch system of Kingda Ka is an engineering marvel. It uses a hydraulic motor to pull a cable attached to the train to speed it up from rest to an incredible speed in a very short amount of time. The system adjusts itself so that the train should always make it over the top of the hill. The reason for these adjustments is largely a result of variable train mass (due to variable weight of the riders). For these problems we are going to assume that the train is traveling its design velocity (as listed in the problems) when it reaches the base of the hill.

31) During launch the train is accelerated from rest to approximately 128 mph (57.2 m/s) in 3.5 seconds. What is the average acceleration of the train over that time period?

- a) 5 m/s^2 b) 10 m/s^2 c) 15 m/s^2 d) 20 m/s^2 e) 25 m/s^2

32) Over what horizontal distance does this acceleration take place?

- a) 50 m b) 75 m c) 100 m d) 125 m e) 150 m

33) Drivers accelerating in a very fast sports car (Corvette, Porsche, etc.) can accelerate from rest to 60 mph (26.8 m/s) in 4 seconds. Pilots launching off the deck of an aircraft carrier accelerate from rest to 135 mph (60.4 m/s) in 2 seconds. Rank each vehicle from slowest to fastest acceleration:

- a) Sports Car – Kingda Ka – Aircraft
b) Sports Car – Aircraft – Kingda Ka
c) Kingda Ka – Sports Car – Aircraft
d) Kingda Ka – Aircraft – Sports Car
e) Aircraft – Kingda Ka – Sports Car

34) If we assume that the mass of the Kingda Ka train and riders is 8325 kg, then how much work is done to accelerate the riders from rest to the velocity they have at the base of the hill?

- a) 10 kJ b) 100 kJ c) 1 MJ d) 10 MJ e) 100 MJ

35) What is the approximate amount of power that Kingda Ka's motor produce to accelerate the train from rest to its maximum velocity?

- a) 4 hp b) 40 hp c) 400 hp d) 4,000 hp e) 40,000 hp

36) As the train changes direction from horizontal to vertical it goes through a curve with a radius of approximately 65 meters. What is the centripetal acceleration of the train as it goes through this point? Provide your answer in "g's" (multiples of 9.8 m/s²).

- a) 1 g b) 3 g c) 5 g d) 7 g e) 9 g

37) Kingda Ka's hill is 137 meters tall. Using the values you recorded for the amount of time for the train to reach the top of the hill and the train's velocity of 57.2 m/s, calculate the magnitude of the average acceleration that the train has on the way up the hill.

- a) 0 m/s^2 b) 4 m/s^2 c) 8 m/s^2 d) 12 m/s^2 e) 16 m/s^2

38) When the train reaches the top of the hill what should the train's theoretical velocity be using the conservation of energy?

- a) 0 m/s b) 5 m/s c) 10 m/s d) 20 m/s e) 40 m/s

39) What was the train's actual velocity as it went over the top of the hill? (To determine velocity use the length of the train – 11.5 m – and the time you measured it took to go over the peak). Calculate what this value should be using the conservation of energy (initial velocity of 57.2 m/s and height of 137 meters). Explain why this value is less than what you calculated by using the conservation of energy. What is causing this reduced speed?

- a) 0 m/s b) 10 m/s c) 20 m/s d) 30 m/s e) 40 m/s

40) At the end of the ride the train goes over a camel hump to give the riders an additional feeling of weightlessness. Using your time that you recorded for the train to go over the peak of this hump and the length of the train to determine the velocity of the train at that point. The radius of this camel hump is approximately 130 meters. What is the net acceleration that the rider feels as a result of going over this camel hump?

- a) 12 m/s^2 b) 6 m/s^2 c) 0 m/s^2 d) -6 m/s^2 e) -12 m/s^2

OPEN ENDED QUESTIONS:

Level I: Kingda Ka does not operate in the rain for the safety of the riders. To understand why this is, calculate the change in the horizontal momentum a falling raindrop would have as it strikes your body. Assume that the raindrop has a radius of 5 mm and a density of 1000 kg/m^3 ; the horizontal velocity of the raindrop is zero; your horizontal velocity is 57 m/s; and the collision between you and the raindrop is inelastic.

A U.S. quarter has a mass of approximately 6 grams. How fast would a quarter have to be moving to provide an equivalent change in momentum as the raindrop (assuming the quarter's collision is also inelastic).

Level II: The change in momentum of one raindrop may not seem like much, but over the course of the ride you would get hit by hundreds to thousands of drops! Assume that you would get hit by about 1000 drops during the course of the ride. How much total force would the raindrops exert on you if the time period over which the drop changes its momentum as a result of hitting you is approximately one-tenth of a second.

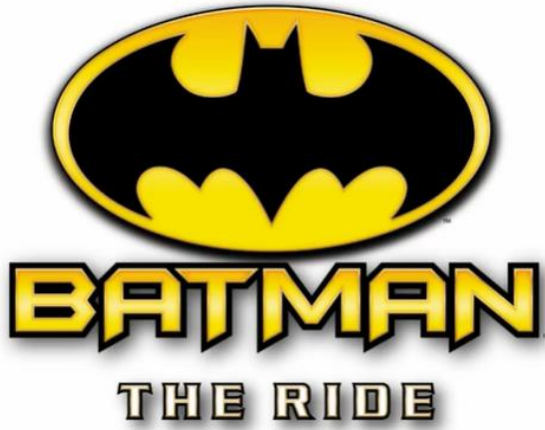

Rider mass: 60 kg

Measurements to make from the ground:

Time it takes for the train to reach the top of the first hill (Point B): _____

Measurements to determine while on the ride (circle the correct value):

Acceleration Factor at point B: **-1.5** 0.0 1.0 3.0 Reading of Acceleration Meter at point D: **-1.0** 0.0 1.0 3.5

Measurement Tools Required		
Acceleration Meter	Angle Meter	Stopwatch / Timer
NO	NO	YES

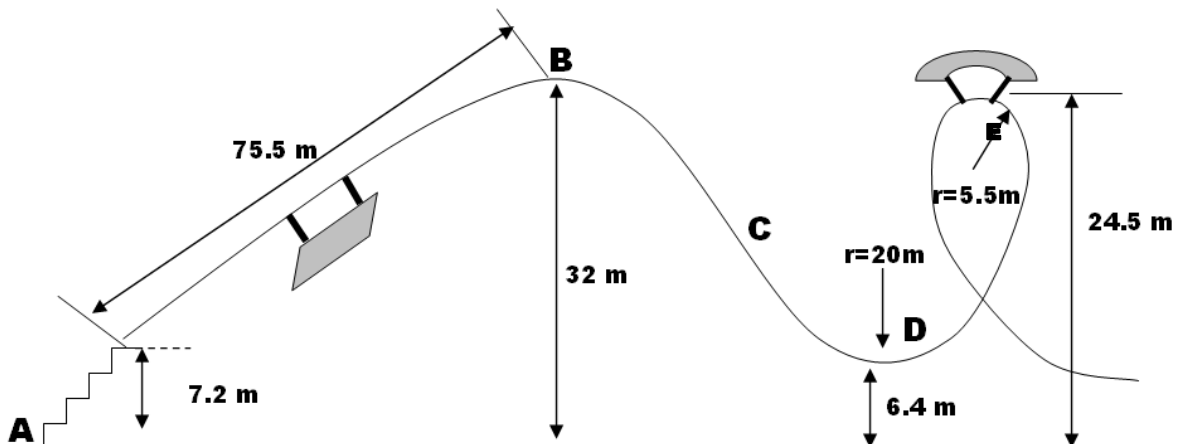

41) Using the ground as your reference level, what is your potential energy at Point B?

- a) 6,000 J b) 12,000 J c) 18,000 J d) 24,000 J e) 30,000 J

Your potential energy at point B is a combination of the work you did to get from ground level to a height of 7.2 meters (by walking up steps) and the work the train did to bring you to point B by riding the coaster.

42) Find the work you did by climbing the stairs to the point where you entered the coaster train.

- a) 100 J b) 600 J c) 1,000 J d) 2,000 J e) 4,000 J

43) What is the work the coaster did on you to get you from the end of the stairs to point B?

- a) 500 J b) 5,000 J c) 15,000 J d) 20,000 J e) 25,000 J

44) What is the power that the ride used to get you to point B?

- a) 50 W b) 200 W c) 500 W d) 1,000 W e) 2,000 W

45) Assuming no energy losses due to friction, what is your total energy at point D?

- a) 6,000 J b) 12,000 J c) 18,000 J d) 24,000 J e) 30,000 J

46) What is your potential energy at Point D?

- a) 4,000 J b) 10,000 J c) 16,000 J d) 22,000 J e) 28,000 J

47) Determine the kinetic energy at point D and use it to calculate your speed at point D.

- a) 5 m/s b) 15 m/s c) 25 m/s d) 35 m/s e) 40 m/s

48) What is the centripetal force on the rider at point D?

- a) 500 N b) 1,500 N c) 2,500 N d) 3,500 N e) 5,500 N

49) Calculate the force the seat exerts on the rider (normal force) at Point D.

- a) 600 N b) 1,200 N c) 2,000 N d) 2,600 N e) 3,400 N

50) Based on your answer for the normal force, what is the calculated Acceleration Meter reading at Point D? How does this compare to your measured Acceleration Meter reading at Point D?

- a) 0.5g b) 1.5g c) 2.5g d) 3.5g e) 4.5g

OPEN ENDED QUESTIONS:

LEVEL I: What is the advantage for Great Adventure in having you walk up the first 7.2 meters of the ride in order to get on as opposed to having the train do it?

LEVEL II: What is the minimum velocity of the train at point D so that it can make it all the way through next loop?



Mass of the train: 2300 kg
Average Passenger Mass: 60 kg

Measurement Tools Required		
Acceleration Meter	Angle Meter	Stopwatch / Timer
NO	NO	YES

Train Passenger Capacity (total # of seats)	Total Mass of Train + Riders (kilograms)	Time for Train to climb Lift Hill (seconds)

SUPERMAN CONSERVATION OF ENERGY DATA TABLE

Point on Height vs. Time Graph	Height above/below reference point (m)	Potential Energy (kJ)	Kinetic Energy (kJ)	Total Mechanical Energy (PE+KE) (kJ)	Velocity (m/s)
A			N/A	N/A	N/A
B			*		**
C					
D					
E					

*Calculate after finding Velocity at B **Found by answering 1st multiple choice question (use exact value)

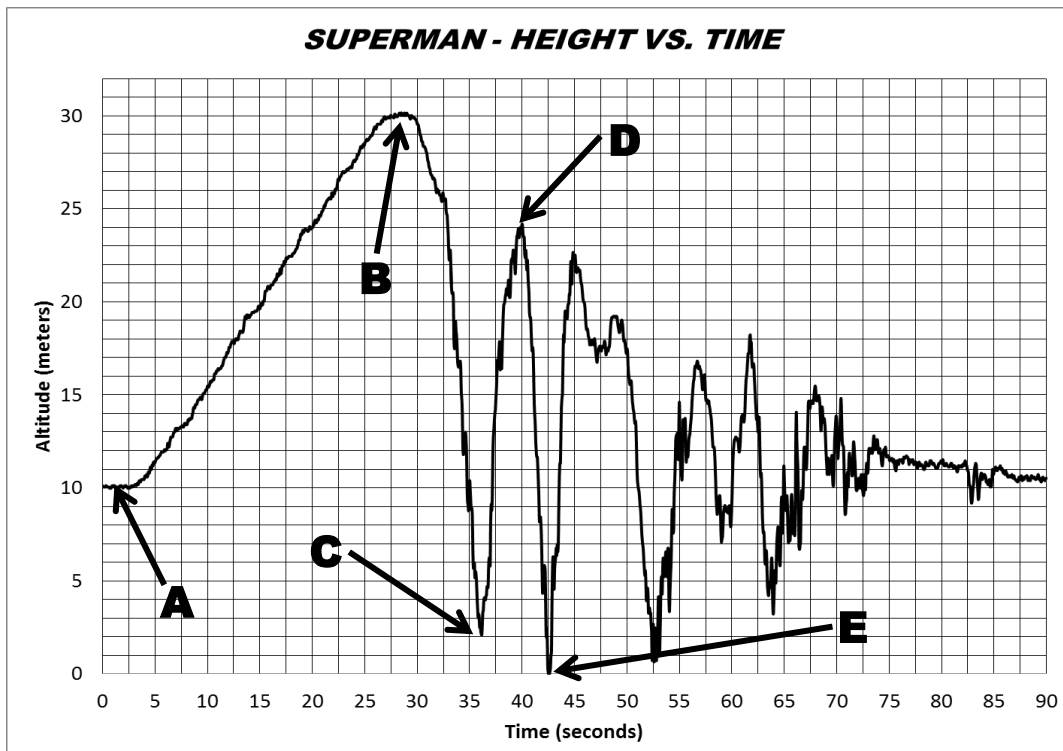

Use Altitude = 0 meters as a reference point for all calculations

51) The linear distance that the train travels up the lift hill to get from Point A to Point B is 47 meters. What was the average linear velocity of the train as it climbed the lift hill? (This is the velocity the train will have at the top of the hill and will allow you to calculate the Kinetic Energy of the train at point B.)

- a) 0.5 m/s b) 1.0 m/s c) 2.0 m/s d) 2.5 m/s e) 3.5 m/s

52) Calculate the work done by the roller coaster's electric motor to increase the train's gravitational potential energy by raising it up the lift hill (fully loaded with all passengers) from Point A to Point B (use the Altitude vs. Time Graph to find Δh).

- a) 40,000 J b) 80,000 J c) 400,000 J d) 800,000 J e) 1,600,000 J

53) What is the minimum average power required from the roller coaster's electric motor to move the train and raise it up the lift hill (fully loaded with all passengers) in the time you measured?

- a) 5 hp b) 25 hp c) 45 hp d) 65 hp e) 85 hp

54) You probably remember climbing a set of stairs in order to reach the loading platform. An elevated platform is part of the ride design, but Six Flags does save energy as a result of you raising your gravitational potential energy instead of the ride having to do it. How much energy does Six Flags save (per fully loaded train) by having the riders to the loading platform at Point A instead of starting the train from ground level (reference point, 0 meters in the graph)?

- a) 190,000 J b) 225,000 J c) 400,000 J d) 625,000 J e) 800,000 J

55) How much extra money would it cost the park if they started the train (with a full load of riders) out from ground level instead of Point A? Assume that the ride is running at a rate of 45 trains per hour, operates for 10 hours per day, the speed of the train on the lift hill would be the same, and the cost of electricity to run the motor that raises the train is \$0.20 per kilowatt-hour.

- a) \$10 b) \$100 c) \$1000 d) \$10,000 e) \$100,000

56) What is the change in the fully loaded train's Potential Energy as a result of going down the first drop hill between Points B and C?

- a) 165,000 J b) 660,000 J c) 1,250,000 J d) 2,200,000 J e) 3,450,000 J

57) At the bottom of the drop hill (Point C), riders travel through a curve with an approximate radius of 25 meters. What is the acceleration factor that the riders experience as they go through Point C?

- a) 1.0 b) 2.0 c) 3.0 d) 4.0 e) 5.0

58) What is the speed of the train at Point D?

- a) 10 m/s b) 16 m/s c) 22 m/s d) 28 m/s e) 34 m/s

59) Point E is at the bottom of a “Pretzel Loop” (its name comes from the pretzel shape formed by the track). At this point riders are lying flat on their backs. What is the velocity of the train at this point?

- a) 32m/s b) 28 m/s c) 24 m/s d) 20 m/s e) 16 m/s

60) Riders experience an acceleration factor of nearly 4.0 at Point E in the “Pretzel Loop”. Using that fact and the speed you calculated in the previous question what is the radius of curvature at the bottom of the “Pretzel Loop”??

- a) 10 m b) 20 m c) 30 m d) 40 m e) 50 m

OPEN ENDED QUESTIONS:

LEVEL I/II: Superman Ultimate Flight is very different from other roller coasters in regard to your body position during the ride. Usually your body’s torso makes a right angle with the roller coaster car floor (and track), so it is appropriate to hold the acceleration meter parallel with your torso. What will happen to your reading as you go through a loop on Superman if you hold the acceleration meter parallel to your torso? What would you be measuring? How do you need to hold the meter in order to measure a true acceleration factor as a result of you changing your direction as you travel through the loop?



Mass of the train: 3200 kg
 Average Passenger Mass: 60 kg

Measurement Tools Required		
Acceleration Meter	Angle Meter	Stopwatch/Timer
NO	NO	YES

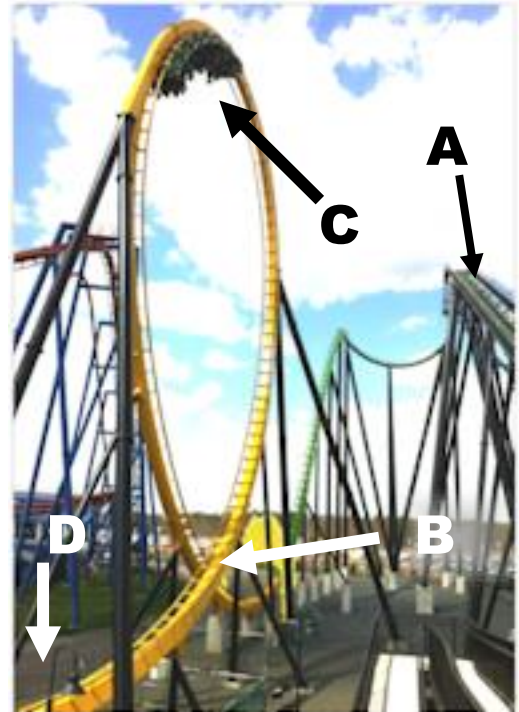

Train Passenger Capacity (total # of seats)	Total Mass of Train plus Riders (kilograms)	Time for Train to climb Lift Hill (seconds)

Sensitive acceleration sensors have been used to determine the Acceleration Factors at Points B, C, and D (see the picture to the right) on Green Lantern. Your job is to ride Green Lantern and determine which Acceleration Factor is the correct value for each point on the ride (B,C,D). You will do this by using your body as the measurement tool – the point where you feel the most force will tell you that the acceleration factor is the largest, where you feel the least force will be the lowest acceleration factor.

The 3 Acceleration Factors measured by the sensors were (smallest to biggest): **0.45, 4.12, 3.39**. After riding, put the correct Acceleration Factor into the table below so it corresponds to the correct Point on the ride.

Acceleration Meter at Base of 1 st Drop (Point B)	Acceleration Meter at Top of 1 st Loop (Point C)	Acceleration Meter at Base after 1 st Loop (Point D)	Time for Train to pass Point E (seconds)

61) Green Lantern’s lift hill has an angle of 26 degrees and is 292 feet long. What is the vertical displacement of the train (and you) to reach Point A as a result of climbing the lift hill?

- a) 21 m b) 39 m c) 62 m d) 80 m e) 99 m

62) Calculate the work done by the roller coaster’s electric motor to increase the train’s gravitational potential energy by raising it up the lift hill (fully loaded with all passengers).

- a) 1.0 MJ b) 1.9 MJ c) 3.0 MJ d) 3.8 MJ e) 4.7 MJ

- 63) What is the minimum average power required from the roller coaster's electric motor to move the train and raise it up the lift hill (fully loaded with all passengers) in the time you measured?
a) 5 hp b) 30 hp c) 60 hp d) 90 hp e) 125 hp

- 64) The station that the train leaves from (where the base of the lift hill is located) is 5.2 meters above the ground. What is the fully loaded train's gravitational Potential Energy after climbing the lift hill at its highest point (Point A)?
a) 1.3 MJ b) 2.1 MJ c) 3.2 MJ d) 4.1 MJ e) 5.0 MJ

- 65) Using the conservation of energy, calculate the speed of the fully loaded train at Point B.
a) 22 m/s b) 29 m/s c) 36 m/s d) 40 m/s e) 45 m/s

- 66) Based on the Acceleration Meter reading you recorded for Point B and the velocity you calculated in the previous problem, what is the radius of the curve at Point B?
a) 11 m b) 21 m c) 29 m d) 43 m e) 65 m

- 67) At Point C the train is upside down in the loop. At this point the radius of the curve the train is moving through is approximately 9 meters. Based on your acceleration meter reading, how high is the train off the ground at Point C?
a) 8 m b) 17 m c) 29 m d) 38 m e) 45 m

68) Based on the Acceleration Factor values for Points B and D, what can you say comparatively about the radius of the curves that the train goes through at each point? Remember to take into consideration the heights of Points B and D relative to the ground in determining your answer.

- a) Point B has a greater radius of curvature
- b) Point D has a greater radius of curvature
- c) The radius of curvature at Points B and D are approximately equal

Explain:

Point E is a position near the end of the ride where the coaster train is at the level of the ground. A good place to observe the train at this point is as you exit the ride and pass by the booth that sells photographs of you taken on the ride (see photos below).

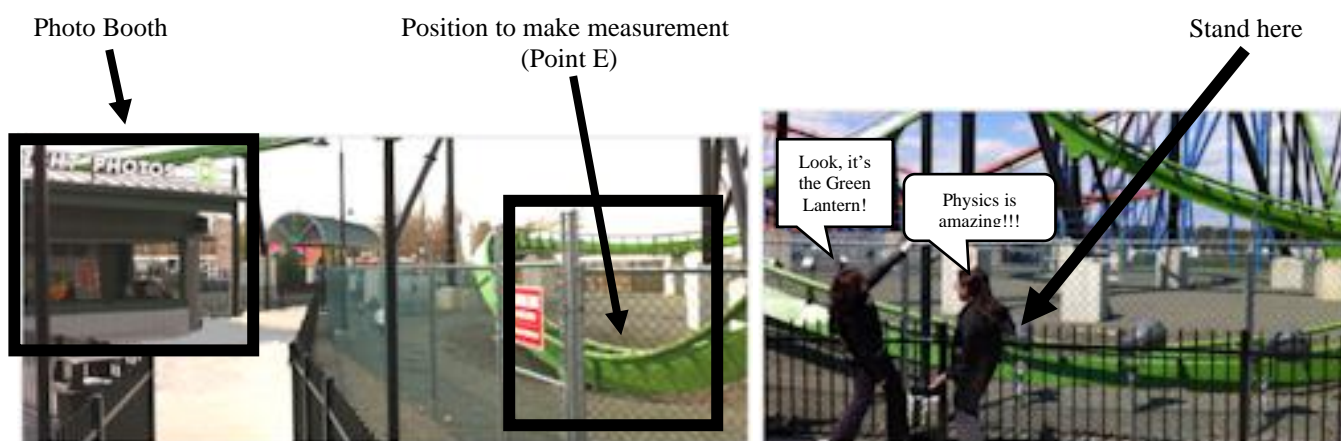

69) Stand near Point E to observe the train as it goes by and measure how long it takes to pass a given point on the track. Use this time and the fact that the train is 39 feet long to determine the speed of the train at Point E.

- a) 11 m/s
- b) 16 m/s
- c) 20 m/s
- d) 24 m/s
- e) 29 m/s

70) At Point E, the actual velocity of the train is less than the theoretical value obtained from the conservation of energy (by conservation of energy the theoretical speed of the train should be approximately 30 m/s). What is the most likely reason that the train was moving slower at Point E?

- a) Friction between the wheels and the track
- b) Air resistance due to the standing riders
- c) Unequal masses of the riders (we assumed all riders to be 60 kg, which is probably untrue)
- d) The roller coaster's motor turning off before Point E

Explain:

OPEN ENDED QUESTIONS:

Level I: Inspect the picture on the first page of the Green Lantern question set. You will notice that after Point A (top of the lift hill) the track takes a small U-shaped dip before going through the first big drop. This is called a “pre-drop” and its purpose is to reduce tension on the lift chain as the train transitions from the lift hill to the point where it is dropped. What effect does this have on the energy and speed of the train later in the ride (particularly at the bottom of the first large drop hill)?

Level II: The Green Lantern is unique among most roller coasters because the riders stand straight up during the ride. How does putting the riders in this orientation change the sensations that the riders feel across their body? Assume a rider is 1.75 meters tall, what is the difference in the acceleration the rider feels from the top of their head to the bottom of their feet? Calculate this using the parameters at Point B, which is at the base of the first large drop hill.

CYBORG

CYBER SPIN



Observe Cyborg Cyber Spin as it operates. Use a timer to measure how long each ring is rotating, count the number of rotations, and put the data in the table below:

	Outer Ring	Middle Ring
Total Rotation Time		
Number of Full Rotations		
Period of Rotation		

Measurement Tools Required		
Acceleration Meter	Angle Meter	Stopwatch / Timer
NO	NO	YES

Cyborg Cyber Spin is a thrill ride that will move you through three axes of motion. The ride consists of 3 rotating “rings” attached to a pair of lifting arms. Once in its upright position each ring is free to move about its axis of rotation, moving riders simultaneously in the X, Y, and Z directions.

As you ride Cyborg Cyber Spin pay attention to the forces that you feel when the ride is at each position in the next three figures. For each position, think about the dominant forces acting on you – when you are upside down do you still feel the force of the seat? Is the shoulder harness pushing against you the hardest?

For each position draw free body diagram arrows on each Figure (A and B) – use the circles at the middle of each figure as the center of mass to indicate what forces are acting on a person at that position.

Forces you may want to include: Force of Gravity (F_g), Force of the seat on the rider (F_N), and the Force of the shoulder restraints in the rider (F_{SR}).

Indicate the magnitude of the force by varying the length of your Force arrows (longer arrows = more force).

Also, describe the relative sensation you feel at each position: Normal, Lighter, Heavier, Weightless, etc.

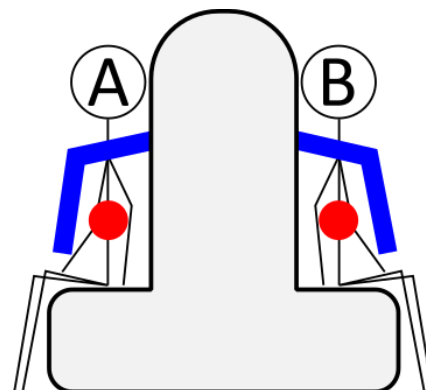
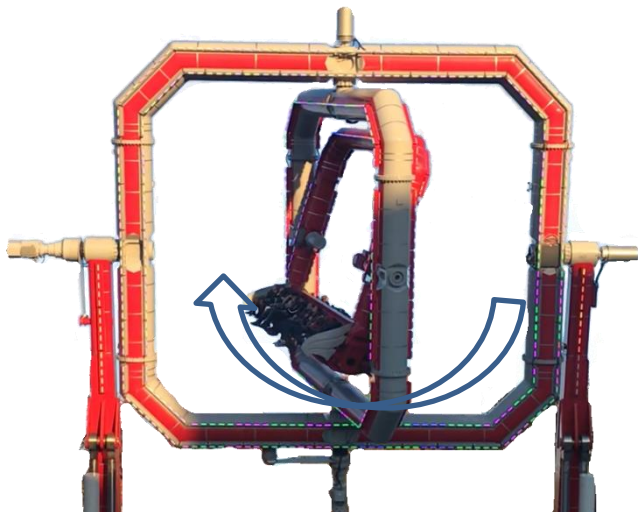

71. Describe the sensation you feel at this position: _____

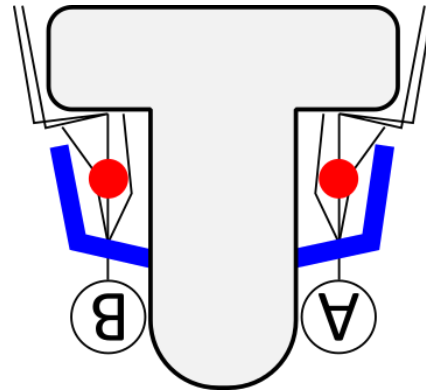

72. Describe the sensation you feel at this position: _____

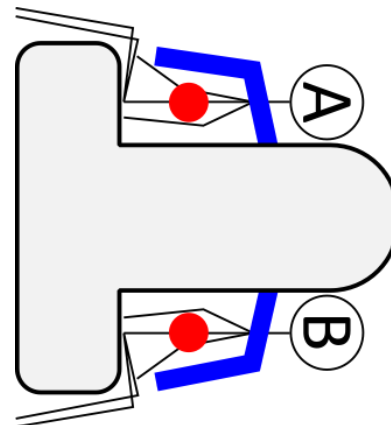
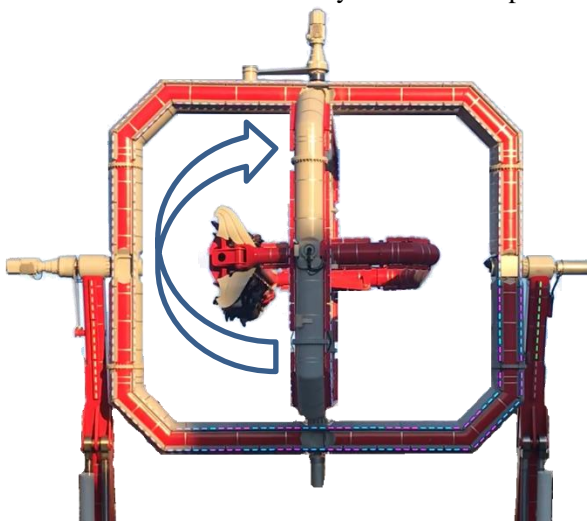

73. Describe the sensation you feel at this position: _____

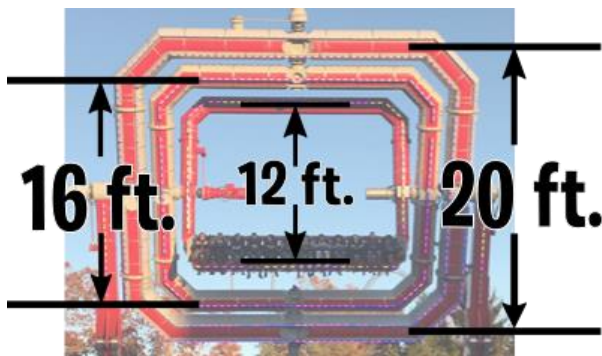

The approximate heights of each of Cyborg's rotating rings is shown to the left.

Use this information and the data you recorded about the period of rotation for each ring to determine the linear speed of each ring

The linear speed of each ring can be found by calculating the total distance a point on the ring sweeps out during one rotation and dividing it by the period of rotation.

74. What distance, in meters, does a point on the Outer Ring travel during a complete rotation?

- a. 9.6 m b. 19.2 m c. 38.3 m d. 62.85 m e. 125.7 m

75. What is the average linear speed of the Outer Ring during a complete rotation?

- a. 0.15 m/s b. 0.5 m/s c. 1.0 m/s d. 2.0 m/s e. 2.5 m/s

76. What distance, in meters, does a point on the Inner Ring travel during a complete rotation?

- a. 2.45 m b. 7.7 m c. 15.4 m d. 30.8 m e. 37.7 m

77. What is the average linear speed of the Inner Ring during a complete rotation?

- a. 0.25 m/s b. 1.0 m/s c. 1.5 m/s d. 2.0 m/s e. 2.5 m/s

78. Watch the motion of the Middle and Outer Rings. How does the speed of the outer ring's rotation affect the speed of the middle ring?

- a. The speed of the middle ring is increased by the speed of the outer ring
 b. The speed of the middle ring is reduced by the speed of the inner ring
 c. Since the rings are oriented at 90° relative to each other, their speeds must be the same
 d. Since the rings are oriented at 90° the middle ring is $\sqrt{2}$ greater than the outer ring
 e. Since the rings are oriented at 90° the speed of the inner and outer rings are independent of each other



Cyborg Cyber Spin keeps riders secure by holding them between two non-moving supports – the seat the rider sits on, and the shoulder restraints. These two supports can provide forces in opposite directions to keep the rider safe no matter the orientation of the ride as it is going through its motion. In some looping roller coasters, riders are travelling fast enough so that shoulder restraints aren't needed to keep the rider from falling when they are upside down – instead the seat needs to provide a force to keep the rider moving in circular motion. (See page 6 for a review.)

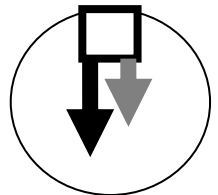

79. Based on the dimensions of Cyborg's inner ring, what is the minimum linear speed a rider would have to be moving with so that the shoulder restraint wouldn't be required to exert a force to hold the rider in place?

- a. 0.5 m/s b. 2.5 m/s c. 3.5 m/s d. 4.5 m/s e. 6.5 m/s

80. Observe Cyborg Cyber Spin in operation – do you think that the rider experience depends on where the rider is sitting (left side, middle, or right side)? Think about the rider's motion relative to the three spinning rings and how their speed may be the same or different based on their position. What would be the cause for different rider experience?

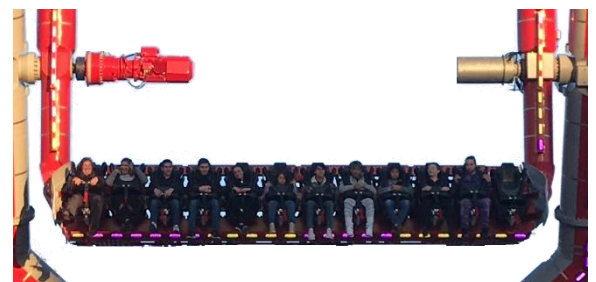



Time for ride to Rise (seconds)	Time for 3 Revolutions (seconds)	Period (seconds)	Angle the Swing makes relative to Vertical (degrees)

Measurement Tools Required		
Acceleration Meter	Angle Meter	Stopwatch / Timer
NO	YES	YES



Sky Screamer is a very tall ride, and as a result it is difficult to measure the angle of the swing if you are too close to it. A good place to stand is near the bumper cars / sky ride area (see picture at upper right). When the ride is moving at maximum speed, measure the angle of the swing relative to the vertical.

This can be a bit tricky – you need to measure the swing whose support arm is perpendicular to you at the moment of your measurement. This occurs on either the left or right side, and is shown by the horizontal line in the picture. You need to hold your angle meter to measure the angle that the riders on the arm make relative to the vertical (those riders are circled in the picture). Remember – you want to know the angle relative to the vertical! There are two vertical lines drawn in the picture for reference.

81. The Sky Screamer lifts riders 200 feet above the ground and swings them in a 98 foot diameter circle. What is the average speed of a rider as they are lifted to the top of the ride?

- a. 1.5 m/s b. 4.5 m/s c. 7.0 m/s d. 9.0 m/s e. 12.0 m/s

82. Watch the Sky Screamer as it lifts riders to the top. Determine a way to estimate the speed of the ride at different points as it ascends. Based on your observations, which value below is most likely correct for the average vertical acceleration of a rider as they are lifted to the top of the ride?

- a. 0 m/s² b. 4.9 m/s² c. 9.8 m/s² d. 14.7 m/s² e. 19.6 m/s²

As the ride is operating and spinning riders in a circle about an axis of rotation, the swing's chairs and chains provide the force in order to keep riders moving in circular motion. The Six Flags website says the riders are swinging in a circle with a diameter of 98 feet when the Sky Screamer is operating at top speed.

83. What is the linear velocity of a rider at top speed?

- a. 11.8 m/s b. 13.4 m/s c. 15.7 m/s d. 18.8 m/s e. 23.5 m/s



84. What is the centripetal acceleration of the rider at top speed?

- a. 9.2 m/s² b. 12.1 m/s² c. 16.4 m/s² d. 23.7 m/s² e. 37 m/s²

85. Compare this value to the predicted acceleration using the equation $a = g(\tan \theta)$ where θ is the angle you measured for the swing relative to the vertical. What is this predicted acceleration?

- a. 8.2 m/s² b. 9.8 m/s² c. 11.7 m/s² d. 14.0 m/s² e. 17.0 m/s²



86. Each seat of the Sky Screamer can accommodate two people. Assuming the mass of the seat is 20 kg and is filled by two 60 kg riders, what is the tension in the chains supporting the seat when the riders sit down (assume they pick their feet off the ground)?

- a. 1175 N b. 1375 N c. 2250 N d. 3000 N e. 4000 N

87. When the ride is operating at full speed the tensile force from the chains is no longer in the same direction as the force of gravity acting on the seat. How does this tensile force when the ride is operating at full speed compare to the tensile force when the ride is not moving (but riders are still in the seat)?

- a. The same b. Larger c. Smaller

88. What is the tension in the chains supporting the seat when the ride is operating at full speed?

- a. 1375 N b. 2250 N c. 3000 N d. 4000 N e. 5800 N

89. Moment of inertia for a rider can be found by multiplying their mass by the square of their distance from the axis of rotation. Multiplying half the moment of inertia by the square of the rider's angular velocity gives the Rotational Kinetic Energy of the rider. These equations are: $I = mr^2$ and $KE = \frac{1}{2} I\omega^2$. What is the moment of inertia for one 60 kg rider moving at top speed and maximum distance from the axis of rotation?

- a. 100 kg m² b. 1000 kg m² c. 10,000 kg m² d. 100,000 kg m² e. 1,000,000 kg m²

90. How much Rotational Kinetic Energy does this rider have when they are moving at top speed?

- a. 50 J b. 5000 J c. 50,000 J d. 500,000 J e. 5,000,000 J

OPEN ENDED QUESTIONS:

Level I: If a rider accidentally releases an object when the ride is at maximum height and top speed, how far away (horizontally) would that object land, assuming negligible air resistance? If viewed from above, what would the path of that object look like?

Level II: The chain that attaches the chair to the support arm is 26.5 feet long. What is the distance from the tip of the support arm (where the seat chains are connected) to the axis of rotation?





Zumanjaro: Drop of Doom is our new record-breaking drop ride that shoots you 41 stories into the sky, then rockets you back to Earth at 90 miles per hour. Pause for a few terrifying moments at the 415-foot peak, then catch a glimpse of the skyscrapers of Philadelphia 52 miles to the south before gravity plunges you back to the ground in less than 10 seconds. Zumanjaro: Drop of Doom is connected to the iconic Kingda Ka — the 456-foot monster that ranks as the world's tallest and fastest coaster in North America. That makes it the tallest drop ride in the world!

Zumanjaro is a “freefall” ride where riders experience the sensation of falling under the influence of gravity only – with no other forces acting on you.

Measurement Tools Required		
Acceleration Meter	Angle Meter	Stopwatch / Timer
NO	NO	YES

Does this ride provide you with a true freefall experience? Is gravity the only force acting on you as you are falling? What other forces could be acting on your system (you and the freefall car you are sitting in)? Support your answers with evidence.

During the freefall, you and the car drop approximately 300 feet before the magnetic brakes bring you safely to rest. Find a location off the ride to watch several drop cycles. Record how much time passes while the car is in freefall (the distance between the two arrows in the picture to the right).

Time 1	Time 2	Time 3	Time 4	Time 5
Average:				

Knowing that the acceleration due to gravity in true freefall is 9.8 m/s^2 , how long would it take an object to fall 300 feet if it was in true freefall? Show your work in the space provided.

Based on the average time you determined from watching the ride, what is the true freefall acceleration that riders experience while dropping 300 feet? Show your work in the space provided.



In most older (and less modern) drop rides the riders experienced a freefall acceleration between 8 m/s^2 and 9 m/s^2 as they fell. How does this compare to Zumanjaro?



Measurement Tools Required		
Acceleration Meter	Angle Meter	Stopwatch / Timer
NO	NO	YES

Direction (CW or CCW) of:		Time (s) for:		Maximum Horizontal Acceleration Card Reading (degrees)
Main Body rotation	Car Body rotation	5 Main Body Rotations	5 Car Body Rotations	
				55

The Main Body of Déjà vu has 3 Arms extending out from its center. Each Main Body Arm is attached to another rotating component called the Car Body. Each Car Body has 4 Car Arms, each attached to a Passenger Car.

- When recording the time for a Main Body rotation watch one of the Main Body Arms – do not watch the cars because it is easy to get confused by the changing motion.
- When recording the time for a Car Body Rotation watch a car and choose a reference point for it to return to. For example, one Car Body rotational period is how much time it takes a car body to start from and get back to the farthest point away from the center of the Main Body.
- When using the Horizontal Acceleration Card rest it on the door directly in front of you. The length of the card must be kept in the radial direction. Record the Maximum reading when the car is at its farthest point from the center of the ride, but also make note to how it changes as the car moves through other positions.
- The distance between the Main Body Arm and its axis of rotation is 4.42 meters.
- The distance between the center of a Car Body and its axis of rotation is 2.67 meters.

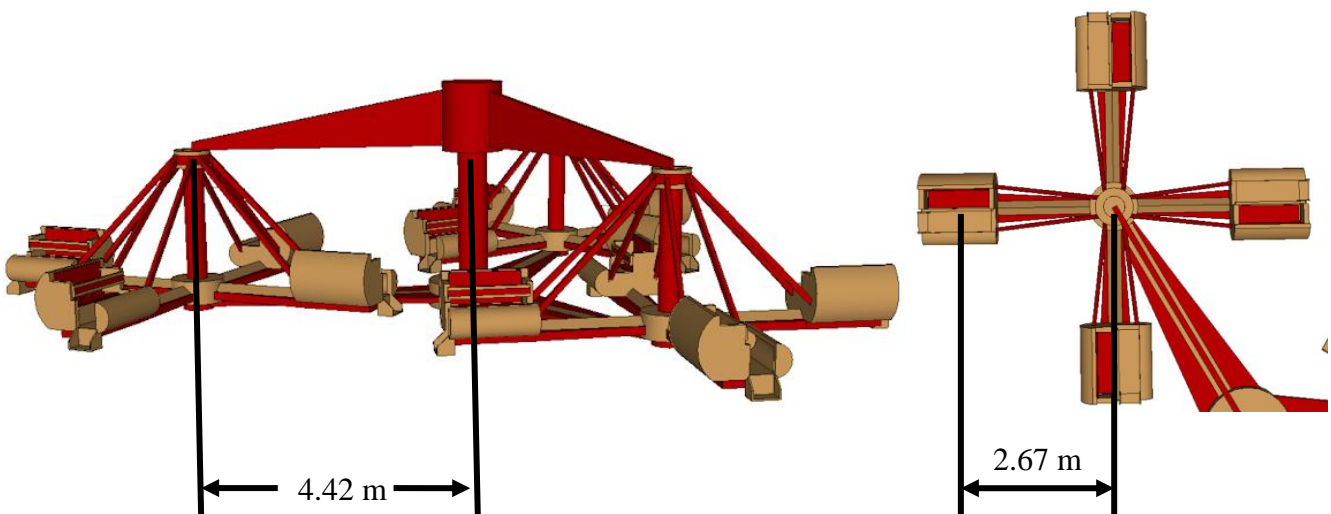

91) What are the periods of rotation for the Main Body and Car Bodies? (Main Body period / Car Body period)

- a) 2.5 s / 2.5 s b. 2.5 s / 5.5 s c. 5.5 s / 5.5 s d. 5.5 s / 2.5 s e. 27.5 s / 12.5 s

The Angular Velocity can be found by dividing the car's travel distance (in radians) by the time it took to travel that distance (in seconds). Remember that the car is traveling in a circle!

92) What is the Angular Velocity of the Main Body?

- a) 0.5 rad/s b. 1.0 rad/s c. 1.5 rad/s d. 2.0 rad/s e. 2.5 rad/s

93) What is the Angular Velocity of the Car Body?

- a) 0.5 rad/s b. 1.0 rad/s c. 1.5 rad/s d. 2.0 rad/s e. 2.5 rad/s

The Tangential Velocity of an object (also referred to as linear speed) can be found by multiplying the object's distance from its axis of rotation and its angular velocity.

94) What is the Tangential Velocity of the Main Body at the point which it is connected to the car body?

- a) 4.25 m/s b. 5.25 m/s c. 6.25 m/s d. 7.25 m/s e. 8.25 m/s

95) What is the Tangential Velocity of the Car Body (relative to its axis of rotation) at the point where a rider sits?

- a) 4.5 m/s b. 5.5 m/s c. 6.5 m/s d. 7.5 m/s e. 8.5 m/s

The Total Velocity of a Déjà vu car can be found by summing the Tangential Velocity Vectors for the Main Body and the Car Bodies. Pay particular attention to the direction of these vectors when the cars are at their a) closest point to the center of the ride, and b) farthest point from the center of the ride.

96) What is a Car's Total Velocity when it is closest to the center of the ride?

- a) 1.5 m/s b. 4.5 m/s c. 7.0 m/s d. 9.0 m/s e. 12.0 m/s

97) What is a Car's Total Velocity when it is farthest from the center of the ride?

- a) 1.5 m/s b. 4.5 m/s c. 7.0 m/s d. 9.0 m/s e. 12.0 m/s

The Centripetal Acceleration of a Déjà vu Car can be found by multiplying the object's distance from its axis of rotation and the square of its total angular velocity. Again, pay attention to the direction of the velocity vectors!

98) What is the Centripetal Acceleration of a Déjà vu Car at its closest point to the center of the ride?

- a) 4.9 m/s² b. 9.8 m/s² c. 13.1 m/s² d. 18.7 m/s² e. 23.4 m/s²

99) What is the Centripetal Acceleration of a Déjà vu Car at its farthest point to the center of the ride?

- a) 4.9 m/s^2 b. 9.8 m/s^2 c. 13.1 m/s^2 d. 18.7 m/s^2 e. 23.4 m/s^2

You used the Horizontal Acceleration Card to measure your centripetal acceleration when you were farthest from the center of the ride. To convert your angular reading to an acceleration you can use the equation $a = g \tan\theta$.

100) What was your centripetal acceleration as directly measured during the ride?

- a) 3.5 m/s^2 b. 8.25 m/s^2 c. 13.5 m/s^2 d. 19.2 m/s^2 e. 26.9 m/s^2

Level I: During the recorded ride safety instructions it says that larger riders should sit towards the outside of the ride. Why do you think this is? Do all riders experience the same forces during the ride or is it dependent on mass?

Level II: During the ride you were asked to report the Horizontal Acceleration Card value only when you were at the farthest point from the center of the ride. However, after completing the questions you found that this may not have been the point where you experienced the maximum acceleration. Why do you think you got the largest (and most easily readable) values when you were at the farthest point from the center of the ride? Shouldn't you have seen larger values using your instrument when you were closest to the ride's center? How does the centripetal acceleration value you measured directly (result of the last question) compare with the value you calculated using angular speed?



Measurement Tools Required		
Acceleration Meter	Angle Meter	Stopwatch / Timer
NO	NO	YES

Measurements to Make:

Time for 5 revolutions at top speed (seconds)	Period of Rotation (seconds)	Number of Cars	Number of times car moves up per revolution	Number of times car moves down per revolution

Rider mass = 60 kg

101) The distance in between Jolly Roger cars, as measured from the center of the car, is 2.4 meters. What is the radius of the circle that the cars travel in during operation of the ride?

- a) 3.05 m b) 6.10 m c) 12.20 m d) 19.20 m e) 38.40 m

102) What is the linear velocity and centripetal acceleration at car's center when the ride is operating at top speed?

- a) 4.3 m/s; 3.1 m/s²
 b) 5.9 m/s; 5.7 m/s²
 c) 6.8 m/s; 7.7 m/s²
 d) 8.1 m/s; 10.5 m/s²
 e) 9.0 m/s; 12.5 m/s²

Each Jolly Roger car has two seats (2 riders per car – see illustration). Rider A is farthest from the axis of rotation, rider B is closest. The car is 4 feet wide, so assume that there are 2 feet in-between the center of mass of each rider.

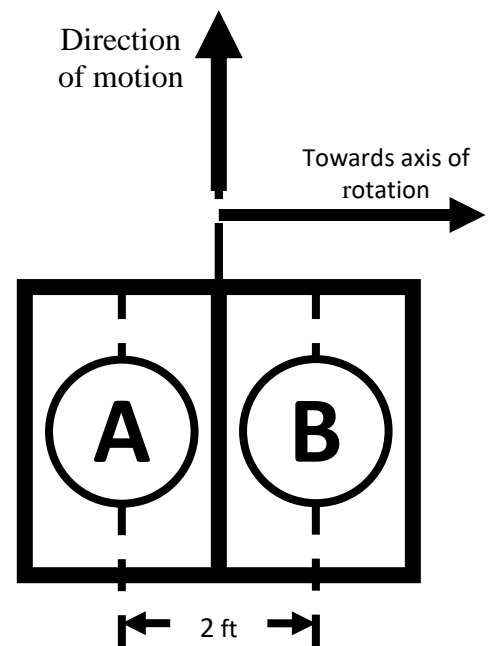

103) When the ride is operating at top speed, which rider completes one full revolution first?

- a) Rider A
- b) Rider B
- c) Both riders complete the revolution at the same time

Explain:

104) When the ride is operating at top speed, which rider has got the greater linear velocity?

- a) Rider A
- b) Rider B
- c) Both riders have the same linear velocity

Explain:

105) When the ride is operating at top speed, you feel a sensation of being pushed in a horizontal direction. Assume that you are riding in Position A from the illustration above. Which way do you 'feel a force' pushing you?

- a) Forwards
- b) To the left
- c) To the right

Explain:

106) To keep you moving in a circle with the ride, something must exert a net force on you (centripetal force) to change your direction. This can be friction from your seat, your seatbelt, the T-Bar you hold on to, or the side of the car. If you were sitting at Position A, how much centripetal force is exerted on you?

- a) 310 N
- b) 325 N
- c) 340 N
- d) 360 N
- e) 375 N

107) If you were sitting at Position B, how much centripetal force is exerted on you?

- a) 310 N
- b) 325 N
- c) 340 N
- d) 360 N
- e) 375 N



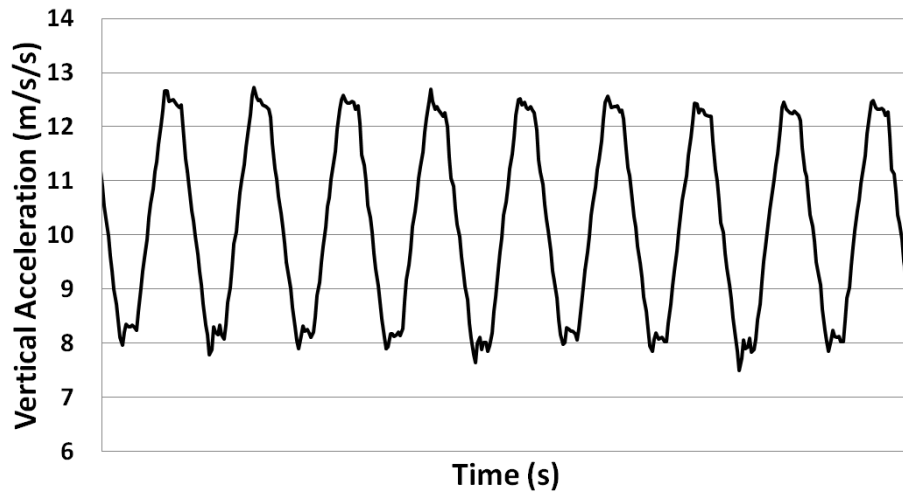

108) The Jolly Roger also moves up and down in a wave-like manner as it goes around in a circle. The vertical displacement of a Jolly Roger is 0.67 meters. What is the average vertical velocity as the car moves up/down?

- a) 0.1 m/s b) 0.6 m/s c) 2.2 m/s d) 4.4 m/s e) 9.7 m/s

109) In addition to the circular motion of the ride providing you with the sensation of being thrown sideways, the wave like motion gives you the sensation of feeling lighter or heavier as you move through the crests and troughs of the wave (similar to the sensations you feel when going through vertical curves on a roller coaster). Using the vertical acceleration graph above, how heavy do you feel when you are moving through a trough of the wave?

- a) 80N b) 125 N c) 480 N d) 590 N e) 750 N

110) Using the above graph, how heavy do you feel when you are moving over the crest of the wave?

- a) 80N b) 125 N c) 480 N d) 590 N e) 750 N

OPEN ENDED QUESTIONS:

LEVEL I: Calculate the minimum coefficient of static friction you would need to have between your pants and the seat in order for you to ride without needing any additional restraints. Consider the circular motion of the ride only. Assume you are sitting at Position A. Do you think it would be safe to ride without the safety restraints? (*I'll answer that one for you – NO*)

LEVEL II: The Jolly Roger also moves up and down as it travels in a circle. Does this vertical motion change the required coefficient of static friction value in order to prevent slipping? Calculate how the coefficient changes as you go over a crest of the wave-like motion and also as you go through a trough.



Radius of ride: 6.0 meters
 Rider mass: 60 kg

Measurement Tools Required		
Acceleration Meter	Angle Meter	Stopwatch/Timer
NO	YES	YES

Measurements to Make:

Time for 5 revolutions at top speed (s)	Period of Rotation (s)	Angle of ride to vertical at full tilt, β^* :

111) What angle (in degrees) does a rider have relative to the horizontal when the ride is at full tilt?

- a) 5 b) 15 c) 25 d) 35 e) 55

112) What is your linear velocity, in m/s, as you are rotating at the ride's top speed?

- a) 2 m/s b) 5 m/s c) 9 m/s d) 14 m/s e) 17 m/s

113) What is the net radial (centripetal) force, in Newtons, needed to keep you moving in a circle at this velocity?

- a) 25 N b) 250 N c) 750 N d) 1000 N e) 1250 N

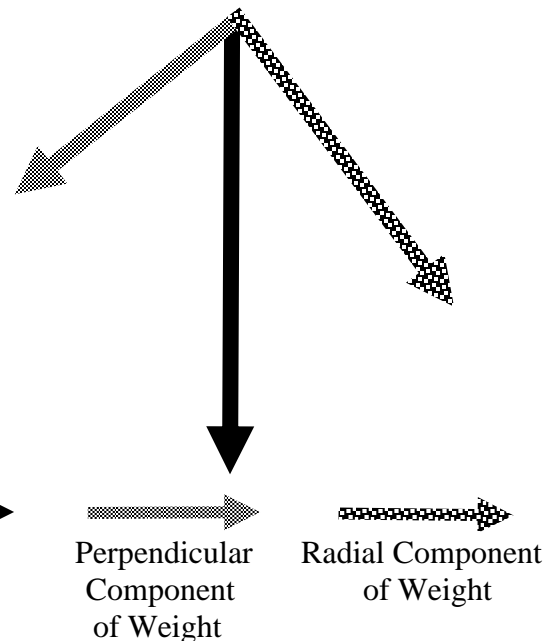
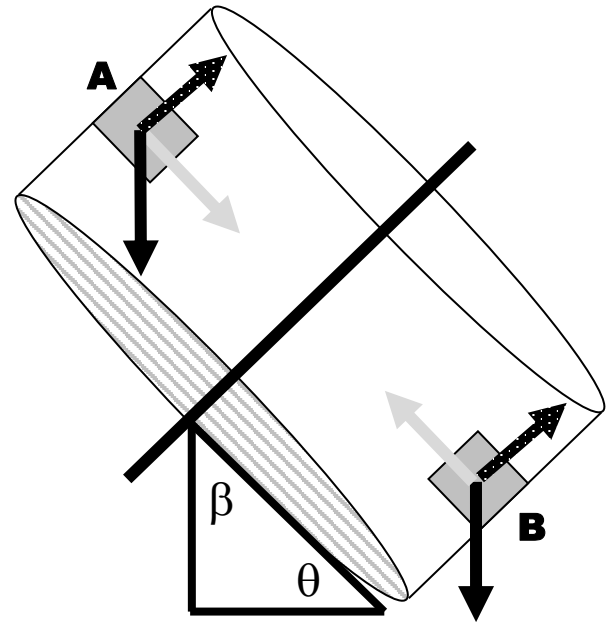

* Using your horizontal acceleration card measure the angle the ride makes with the horizontal (θ) as shown in the picture, then subtract that from 90° to find β

114) When the ride is horizontal (no tilt), the entire radial force is exerted by the wall on your back. What would be the Acceleration Meter reading when the ride is horizontal and moving at top speed (this is calculated, not measured)?

- a) 0.25 b) 0.50 c) 0.75 d) 1.00 e) 1.25

For the next two questions the ride is tilted to its maximum angle, β (your measurement), and the rider is at position A (see the figure on the previous page). Your weight vector now has a component that is in the radial direction – here it is pointed towards the axis of rotation. Remember to assume that your mass is 60 kg.

115) What is the component of your weight, in Newtons, in the radial direction?

- a) 25 N b) 75 N c) 150 N d) 350 N e) 500 N

116) What is the force, in Newtons, that the wall must contribute to keep you moving in a circle? (Remember that your weight now contributes to the radial force as calculated in the previous question.)

- a) 50 N b) 100 N c) 250 N d) 400 N e) 550 N

For the next two questions we will examine what happens when you are at the lowest point with maximum tilt (position B in the figure on the previous page - 180° from your maximum height position). Your weight vector now has a component that is in the radial direction – but pointed away from the axis of rotation. Remember to assume that your mass is 60 kg.

117) When you are at the lowest point, what is the component of your weight, in Newtons, in the radial direction?

- a) 25 N b) 75 N c) 150 N d) 350 N e) 500 N

118) When you are at the lowest point, what is the force (N) that the wall must contribute to keep you moving in a circle?

- a) 500 N b) 1000 N c) 1500 N d) 2000 N e) 2500 N

119) What would the ride's minimum speed need to be, in m/s, so that you are not in danger of falling towards the ride's center when you are at position A and the ride is tilted at its maximum angle?

- a) 2 m/s b) 6 m/s c) 10 m/s d) 15 m/s e) 19 m/s

120) This ride would become very uncomfortable if it was rotating fast enough so that you experienced a force of about 4 g's. When the ride is horizontal (not tilted), at what velocity, in m/s, would you experience this force?

- a) 2 m/s b) 6 m/s c) 10 m/s d) 15 m/s e) 19 m/s

OPEN ENDED QUESTIONS:

LEVEL I: The ride operator thinks that the ride would be safer if he reduces the velocity at which the ride rotates. Why is this not a good idea?

LEVEL II: Show mathematically that the rider will not fall towards the center of the ride (with sufficient velocity) at a given angle θ , regardless of the mass of the rider.

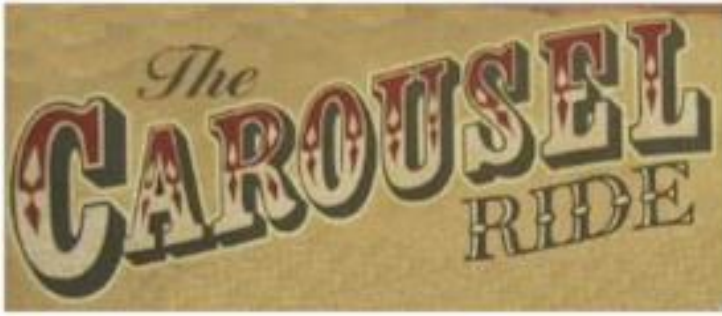

Measurement Tools Required		
Acceleration Meter	Angle Meter	Stopwatch/Timer
NO	NO	YES

Measurements to Make:

Time for 5 revolutions at top speed	Number of horses in the outer ring	Spacing between horses in the outer ring	Distance from center to outer horses	Number of horses in the inner ring	Spacing between horses in the inner ring	Distance from center to inner horses
		2.62 m			1.83 m	

Mass of rider: 60 kilograms

121) What is the period of the merry go round in seconds?

- a) 1 s b) 3 s c) 6 s d) 15 s e) 23 s

122) What is the frequency of the merry go round in cycles per second?

- a) 0.05 Hz b) 0.07 Hz c) 0.17 Hz d) 0.33 Hz e) 1.00 Hz

123) What is the circumference of the outer ring of horses?

- a) 10 m b) 15 m c) 20 m d) 25 m e) 30 m

124) What is your linear speed if you are standing next to one of the horses in the outer ring?

- a) 1.0 m/s b) 2.0 m/s c) 3.0 m/s d) 4.0 m/s e) 5.0 m/s

125) What is the centripetal force acting on you if you are standing next to one of the horses in the outside ring?

- a) 50 N b) 100 N c) 150 N d) 200 N e) 600 N

126) What is your linear speed if you are standing next to one of the horses in the inner ring?

- a) 0.5 m/s b) 1.5 m/s c) 2.5 m/s d) 3.5 m/s e) 4.5 m/s

127) What is the centripetal force acting on you if you are standing next to one of the horses in the inner ring?

- a) 10 N b) 40 N c) 70 N d) 110 N e) 600 N

128) What is the normal force that the floor is exerting on you?

- a) 0 N b) 30 N c) 60 N d) 300 N e) 600 N

129) What must be the minimum coefficient of friction (μ) to prevent you from slipping off the ride when you are standing next to one of the outer ring horses?

- a) 0.01 b) 0.10 c) 0.25 d) 0.50 e) 0.75



130) If you move so that you are now standing next to one of the inner ring horses, what will happen to the minimum coefficient of friction so that you do not slip off the ride? Explain why.

- a) It remains the same b) It increases c) It decreases

OPEN ENDED QUESTIONS:

LEVEL I: For safety purposes the ride's floor is coated with a non-stick surface that has a coefficient of friction with the average pair of sneakers equal to 0.7. With this coefficient of friction, how fast would the rider have to be moving while standing next to one of the outer ring horses to be thrown off the ride?

LEVEL II: Prove mathematically that μ is independent of the mass of a rider who is located at a fixed location from the ride's axis of rotation.



Measurement Tools Required		
Acceleration Meter	Angle Meter	Stopwatch/Timer
YES	YES	YES

Measurements to Make:

Time for one complete swing: _____

Maximum angle with the vertical: _____

Acceleration Meter Readings		
Position A	Position C	Position E

While in line record the period of the ride's motion and maximum angle with the vertical – do this when the ride is at its maximum amplitude using the ship's mast to measure against. While riding record g-force (Acceleration Meter) readings – you should sit as close to either end of the ship as possible for best results.

For the questions below answer as if you were sitting on the **RIGHT SIDE** of the ship (as you are looking at it as in the picture above). If you sat on the left side during the ride your answers will simply be opposite of what you experienced.



Position A



Position B



Position C



Position D



Position E

131) According to your Acceleration Meter, when the ride is in motion at what point in the ride do you feel the lightest?

- a) A
- b) B
- c) C
- d) D
- e) E

132) According to your Acceleration Meter, when the ride is in motion at what point in the ride do you feel the heaviest?

- a) A
- b) B
- c) C
- d) D
- e) E

For the next six questions you will need to make calculations that require how high the rider is above their minimum height. To do this, use the conservation of energy and the fact that the radius of the ship's motion is approximately 12 meters. Assume that very little energy is lost to friction. Consult the figure below that shows how to determine the rider's height above the minimum point. Theta is the angle that the ship made with the vertical as measured against the ship's mast.

133) Using your reading for the maximum angle you have made with the ground, calculate the height of the rider.

- a) 3 m b) 6 m c) 9 m d) 15 m e) 20 m

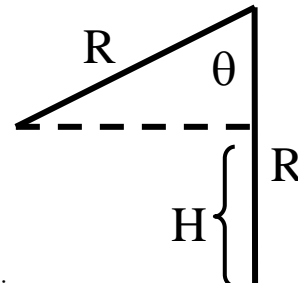

134) Calculate the maximum potential energy (Position E) that a 60 kg rider has during the ship's swing.

- a) 3,500 J b) 5,500 J c) 6,000 J d) 12,000 J e) 15,500 J

135) Calculate the maximum velocity that a 60 kg rider has during the ship's swing.

- a) 2 m/s b) 10 m/s c) 18 m/s d) 26 m/s e) 34 m/s

136) The previous questions assumed that the rider was sitting at the center of the ship. If the rider was instead sitting on the far right or left end of the ship how would their maximum potential energy compare to a rider in the center?

- a) It would be less b) It would be the same c) It would be more

Explain why you made your choice.

137) If we assume that Position D is when the ship is at 1/2 the angle it makes with the vertical at Position E, then what fraction of the maximum potential energy will the rider have at Position D?

- a) 10% b) 30% c) 50% d) 70% e) 90%

138) If we assume that Position D is when the ship is at $\frac{1}{2}$ the angle it makes with the vertical at Position E, then what fraction of the maximum velocity will the rider have at Position D?

- a) 10% b) 30% c) 50% d) 70% e) 90%

139) The Buccaneer has the appearance of a large pendulum. Calculate the theoretical period that the Buccaneer would have based on its length of 12 meters. Is this close to your recorded period?

- a) 2.0 s b) 3.5 s c) 7.0 s d) 10.5 s e) 14.0 s

140) Assuming that the Buccaneer does behave like a large theoretical pendulum, how by how much does the period of its swing increase by when it is fully loaded (total mass of 12,000 kg with passengers) vs. when it is empty (7000 kg)?

- a) 0% b) 25% c) 50% d) 75% e) 100%

OPEN ENDED QUESTIONS:

LEVEL I: Below is a graph actual data collected by a Buccaneer rider sitting in the middle of the ship using a computerized accelerometer and altimeter. The acceleration data (g-force) is represented with the solid line, and the altimeter (height) data is represented with the dashed line. A time data point and the 1-g data point have been added to their axis as reference values. Based on your measurements, fill in the empty boxes with the corresponding time and g-force values.

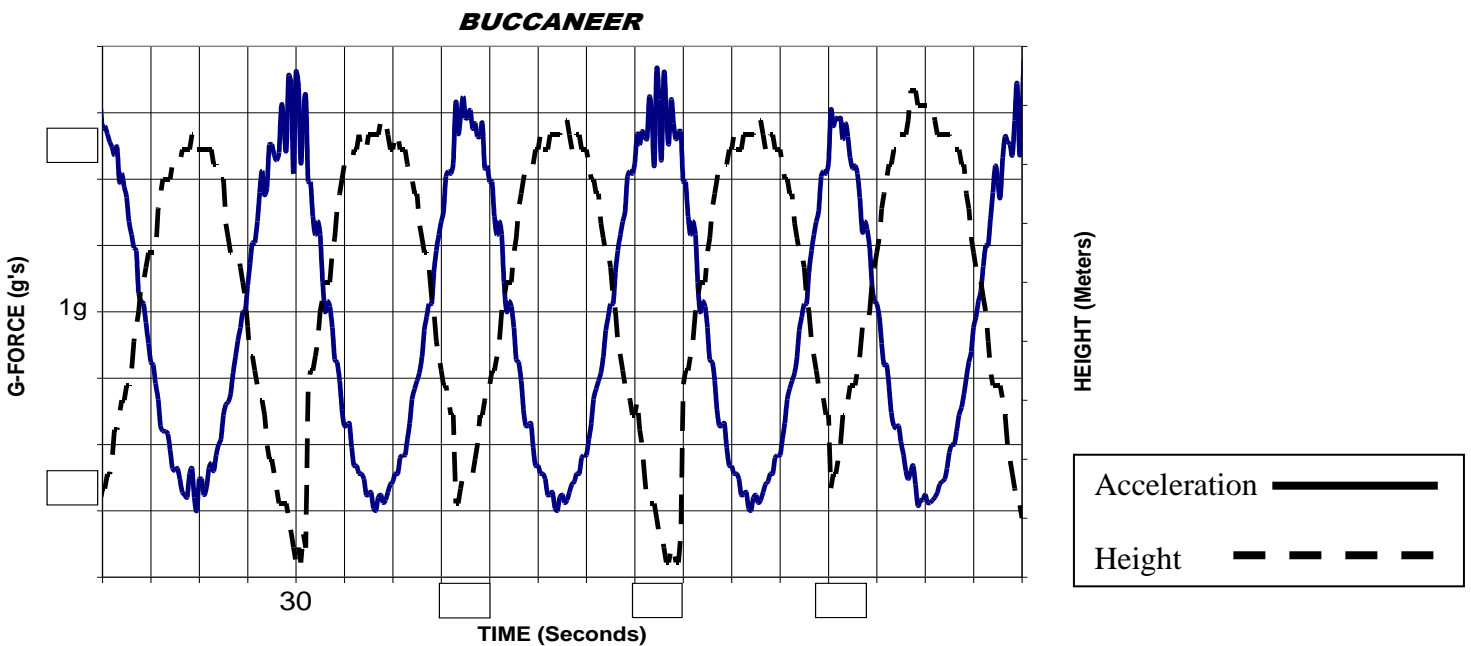

LEVEL II: Compare the graph from the previous question (where the rider was sitting in the middle of the ship) to the one below. The acceleration data (g-force) is represented with the solid line, and the altimeter (height) data is represented with the dashed line. Where in the ship was the person who collected that data sitting? How can you tell? (Answer below)

BUCCANEER

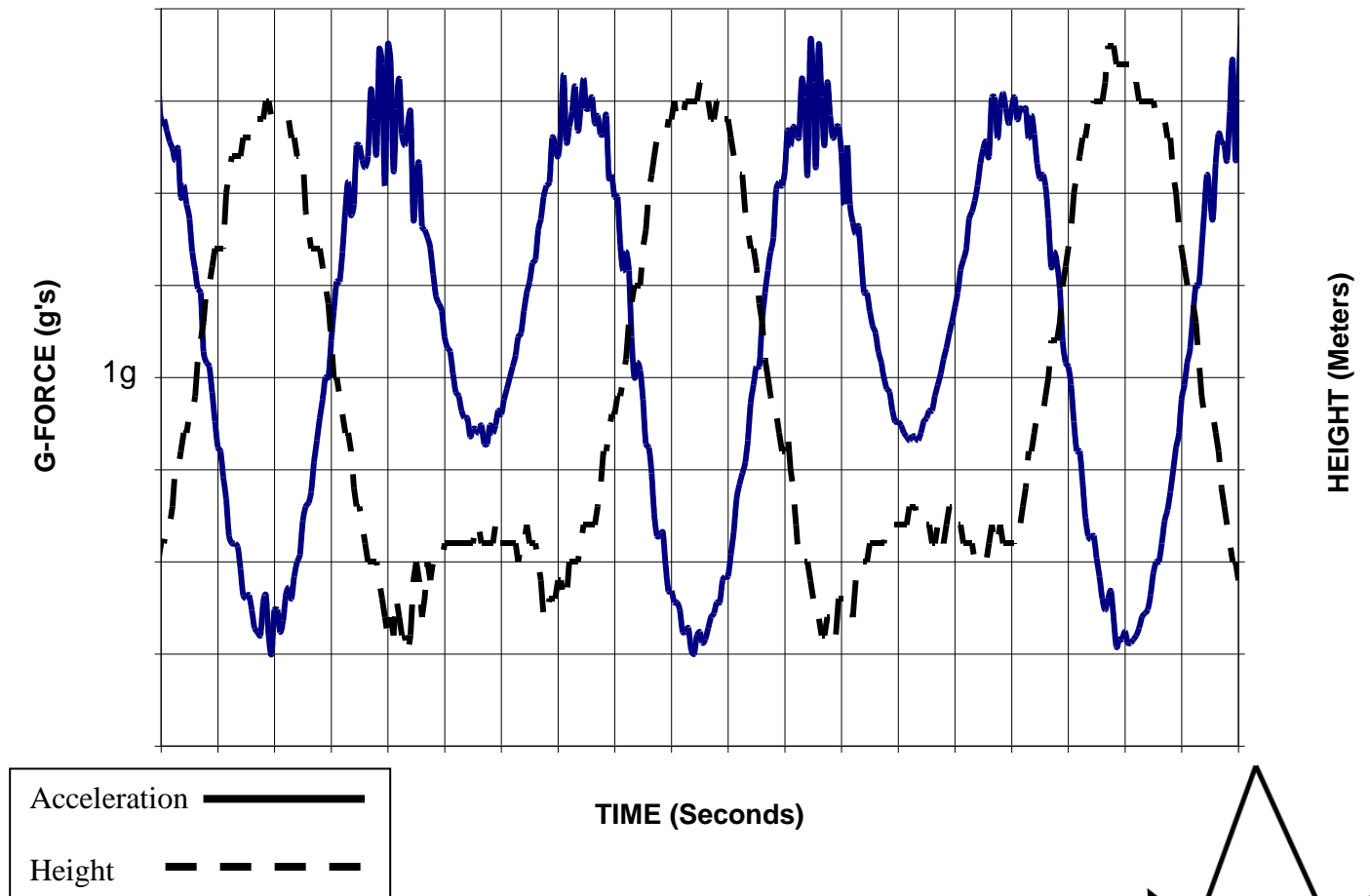

Where could the person have been sitting on the ship? (See figure on right)

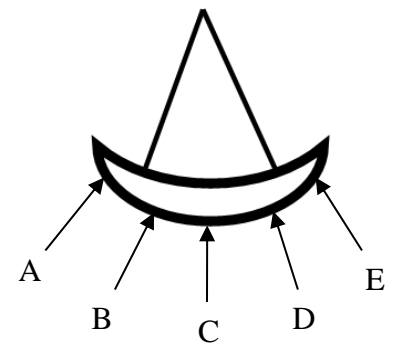

What did you notice in the graph about the g-forces acting on that person that led you to believe this?

What did you notice about that person's altitude (height above the ground) that influenced your decision?

THE BIG WHEEL

Measurement Tools Required		
Acceleration Meter	Angle Meter	Stopwatch / Timer
NO	NO	YES

Measurements to Make:

Count the number of:				
Colored Sections	Cars Per Colored Section	Total Cars	Time for 5 revolutions (at top speed)	Number of lights between cars*

*(see photo below – at the park count the lights between the two arrows)



141) In 2009 the Big Wheel’s 7,824 incandescent lights were replaced with more energy-efficient LED lights. Each old (incandescent) light consumed 7 watts of power. The new LED lights only consume 2 watts of power each. How much power is saved due to this light conversion? (Include all the lights for your calculation.)

- a) 5 kW b) 50 kW c) 500 kW d) 5 MW 50 MW

142) The lights on the Big Wheel are turned on for an average of three hours per day during the 180 day operating season. How much energy, in kilowatt hours, does the Big Wheel’s light conversion save during the course of a year?

- a) 1,000 kWhr b) 10,000 kWhr c) 20,000 kWhr d) 40,000 kWhr e) 80,000 kWhr

143) If the park is charged 18 cents per kilowatt hour, what is the yearly cost savings as a result of replacing these lights?

- a) \$1000 b) \$5000 c) \$10,000 d) \$25,000 e) \$100,000

144) What is the period of rotation for the Big Wheel when it is operating at full speed?

- a) 10 s b) 20 s c) 40 s d) 80 s e) 160 s

145) The distance in between each light along the perimeter of the Big Wheel is 7.5 inches (19.05 cm). What is the circumference of the Big Wheel?

- a) 50 m b) 75 m c) 100 m d) 125 m e) 150 m

146) What is the linear velocity of a car when the Big Wheel is at top speed?

- a) 0.5 m/s b) 1.0 m/s c) 1.5 m/s d) 2.5 m/s e) 3.0 m/s

147) What is the radius of the Big Wheel?

- a) 5 m b) 10 m c) 15 m d) 20 m e) 30 m

148) What is the centripetal acceleration on a Big Wheel rider at top speed? What is the direction of this acceleration?

- a) 0.5 m/s^2 b) 1.5 m/s^2 c) 2.5 m/s^2 d) 3.5 m/s^2 e) 4.5 m/s^2

149) How much work does the Big Wheel do on a group of riders to raise them from the lowest point to the highest point on the wheel? The riders are in the same car and they have a combined mass of 300 kg.

- a) 3000 J b) 30,000 J c) 75,000 J d) 125,000 J e) 225,000 J

150) How much power is required to lift this group of riders when the Big Wheel is operating at its top speed?

- a) 3 kW b) 7.5 kW c) 15 kW d) 22.5 kW e) 30 kW

OPEN ENDED QUESTIONS:

LEVEL I: Notice the manner in which the ride operator loads the cars. The operator will not load too many consecutive cars (usually only two or three) with passengers; instead they try to space riders out evenly around the wheel. Why is this important to do in order to maintain safe and efficient operation of the Big Wheel?

LEVEL II: Imagine that you are the Big Wheel ride operator. You begin the day with 25 people waiting to be loaded onto the ride, 4 groups of 4 people, and 3 groups of 3 people (assume each person has approximately the same mass). There are 36 total cars. How would you space these groups out on the Big Wheel? Explain why you chose to space them this way. (Answer by drawing a picture or describing the angular separation between groups.)

NOTES / CALCULATIONS PAGE